

REV.	DATE	DRAWN	REVISION
A	16APR2002	MJS	UPDATED LOGO

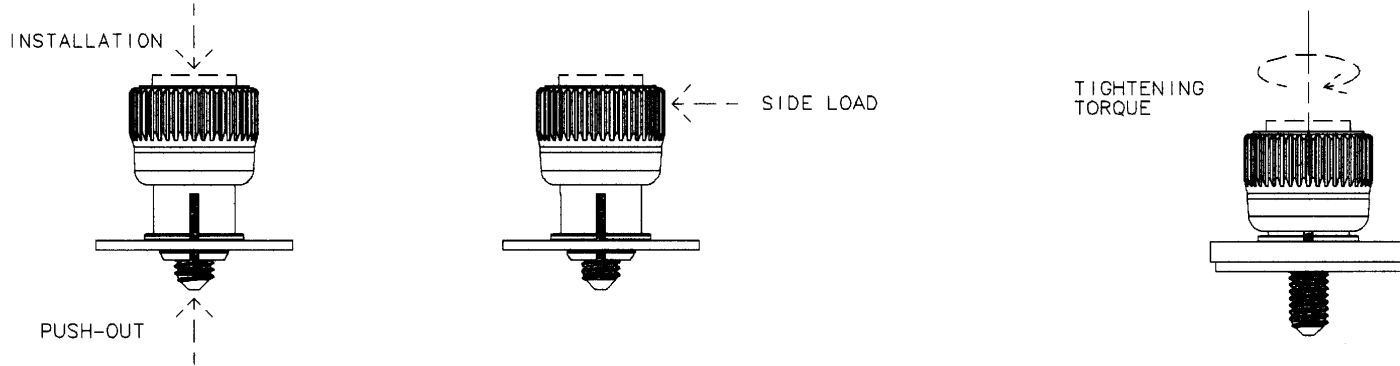

SOUTHCO PERFORMANCE GUIDELINES
THE PERFORMANCE GUIDELINES SHOWN ON THIS PAGE ARE SUPPLIED AS A GENERAL GUIDE ONLY, AS CONDITIONS VARY WITH EACH APPLICATION AND METHOD OF INSTALLATION. STRENGTH DATA GIVEN IS FOR FAILURE OF THE PRODUCT OR FOR SUFFICIENT DEFORMATION TO MAKE PRODUCT INOPERABLE. NO SAFETY FACTOR HAS BEEN APPLIED. IT IS RECOMMENDED THAT THE USER REQUEST A PRODUCT SAMPLE FOR TESTING TO DETERMINE THE SUITABILITY OF THE PRODUCT FOR THE PURPOSE INTENDED AND USER'S PARTICULAR APPLICATION.



PANEL THICKNESS mm (in)	ASSEMBLY NUMBER ①	AVERAGE INSTALLATION FORCE N (lbf)	AVERAGE PUSH-OUT FORCE N (lbf)	AVERAGE SIDE LOAD N (lbf)	AVERAGE TIGHTENING TORQUE TO FAILURE N·cm (lbf·in) ⑦
0.5 (.020) TO 1.0 (.039)	47- $\frac{6}{8}$ X-2XX-XX	198 (45)	451 (101)⑤	143 (32)⑤	341 (30)⑧
	47- $\frac{6}{8}$ X-3XX-XX	176 (40)	704 (158)⑥	215 (48)⑥	627 (55)⑧
	47- $\frac{6}{8}$ X-5XX-XX	198 (45)	717 (161)⑥	219 (49)⑥	636 (56)⑧
1.0 (.039) TO 1.6 (.063)	47- $\frac{6}{8}$ X-2XX-XX	185 (42)	232 (52)⑤	148 (33)⑥	401 (35)⑧
	47- $\frac{6}{8}$ X-3XX-XX	162 (36)	642 (144)⑤	242 (54)⑥	702 (62)⑧
	47- $\frac{6}{8}$ X-5XX-XX	206 (46)	504 (113)⑥	248 (56)⑥	669 (59)⑨
1.6 (.063) TO 2.5 (.098)	47- $\frac{6}{8}$ X-2XX-XX	588 (110)	1080 (243)⑧	242 (54)⑥	394 (35)⑧
	47- $\frac{6}{8}$ X-3XX-XX	259 (58)	502 (113)⑥	163 (37)⑥	384 (34)⑧
	47- $\frac{6}{8}$ X-5XX-XX	376 (85)	459 (103)⑥	164 (37)⑥	638 (56)⑧

NOTES:

- ①. ALL ASSEMBLIES TESTED IN CRS ASTM A 109, #5 TEMPER (Rb43).
- ②. TESTED IN 0.8 mm (.031") THICK PANELS.
- ③. TESTED IN 1.6 mm (.062") THICK PANELS.
- ④. TESTED IN 2.4 mm (.093") THICK PANELS.
- ⑤. FAILURE OCCURRED WHEN ASSEMBLY RELEASED FROM PANEL.
- ⑥. FAILURE OCCURRED WHEN ASSEMBLY RELEASED FROM PANEL WITH FERRULE LEG DAMAGED, SCREW PUSHED OUT OF ASSEMBLY OR KNOB UNCRIMPED FROM ASSEMBLY.
- ⑦. SLOTTED DRIVE RECESS TESTED.
- ⑧. FAILURE OCCURRED WHEN SCREW SHANK BROKE, DRIVE RECESS STRIPPED OR THREADS STRIPPED.
- ⑨. FAILURE OCCURRED WHEN THREADS STRIPPED.