

**southco**  
 PROPRIETARY ITEM - EXCEPT FOR USES EXPRESSLY GRANTED IN WRITING INFORMATION IS UNCLASSIFIED. HEREON IS CONFIDENTIAL AND ALL RIGHTS, PATENT AND OTHERWISE ARE RESERVED BY SOUTHCO, INC.

REV	DATE	DRAWN/CHKD	DESCRIPTION
A	03NOV2008	IR/DLH	RELEASED FOR PRODUCTION
B	25NOV2008	IR/ACH	PRN: P2008-1345
C	04 FEB 09	IR/ACH	PRN: P2009-0162
D	22SEP2014	CMS/BGL	PRN: P2014-1872
E	05AUG2016	CMS/IR	PRN: P2016-1835
F	08OCT2018	CMS/CDW	PRN: P2018-2334

DRAWING NUMBER	DRAWING CHKD	SCALE	DATE	MATERIAL	DESCRIPTION	FINISH/COLOR	DESCRIPTION	MATERIAL
J-H3-50-301-1	IR	ACH	15 MAY 08	STEEL	DISC SPRING	BLACK POWDERCOAT	HOUSING	ZAMAC 3
MILLIMETERS	IR	ACH		STAINLESS	DUMMY CAM	NATURAL	TOOL ACTUATOR	SANTOPRENE
ALL DIMENSIONS WITHOUT TOLERANCES ARE FOR REFERENCE ONLY.					WAVE WASHER	CHROME PLATE	ROTATION LIMITER	BUNA-N
					RETAINER	NATURAL/BLACK	LOCKING PLUG	
					HANDLE PIN		DIN LOCK ASSY	
					PANEL SPRING		PANEL GASKETS	
					WAVE WASHER		DIN DUST COVER	
					PADLOCK HASP		HANDLE BUMPER	
					SHAFT O-RING			
					SCREW O-RINGS			

PART NUMBER: H3-50-**A** **LL** **CCC** -1 **FF**

PADLOCK/SERIES:

- 1, 2 = COVERED IN J-H3-50-101-0 OR J-H3-50-101-1
- 3 = NO PADLOCK, ACTUATOR
- 4 = PADLOCK, ACTUATOR

LOCKING OPTION:

- 00 = NO LOCK PROVIDED (DIN ONLY)
- 01 = CH751
- 02 = 300
- 03 = 333
- 04 = NON LOCKING
- 10 = RS CODES
- 11 = LS CODES
- 20 = NON LOCKING DIN WITH DETENT
- 21 = DIN CH751
- 22 = DIN 300
- 23 = DIN 333
- 24 = DIN, W/O LOCK PLUG
- 40 = TOOL, 3mm DOUBLE BIT
- 41 = TOOL, 5mm DOUBLE BIT
- 42 = TOOL, TELCORDIA 216 (BELLCORE)
- 43 = TOOL, ELECTRONICS KEY
- 47 = TOOL, 8mm TRIANGLE
- 70 = DIN TOOL, 3mm DOUBLE BIT
- 71 = DIN TOOL, 5mm DOUBLE BIT
- 72 = DIN TOOL, TELCORDIA 216
- 73 = DIN TOOL, ELECTRONICS KEY
- 77 = DIN TOOL, 8mm TRIANGLE

ASSEMBLY FINISH:  
 44 - SATIN CHROME  
 50 - BLACK POWDER COAT  
 OTHERS AVAILABLE UPON REQUEST

GRIP TABLE  
 CAM  
 PART No. E5-61YY

YY	GRIP	YY	GRIP
07	10.3	15	26.3
08	12.3	16	28.3
09	14.3	17	30.3
10	16.3	18	32.3
11	18.3	19	34.3
12	20.3	20	36.3
13	22.3	21	38.3
14	24.3	22	40.3

SEE J-E5-61-A (FLAT CAM)  
 SEE J-E5-71 (ROLLER CAM)

CAM SOLD SEPARATELY SEE CAM GRIP TABLE AND J-E5-61-A

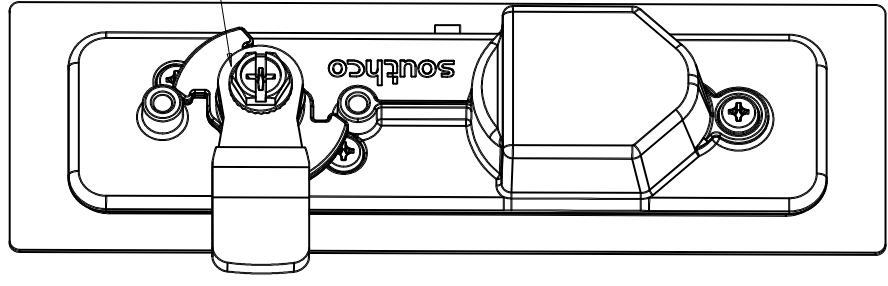

H3-50-303-1XX SHOWN AS A SINGLE POINT LATCH

CAM SOLD SEPARATELY SEE CAM GRIP TABLE AND J-E5-61-A. USE DUMMY CAM FOR NO CENTER POINT LATCHING.

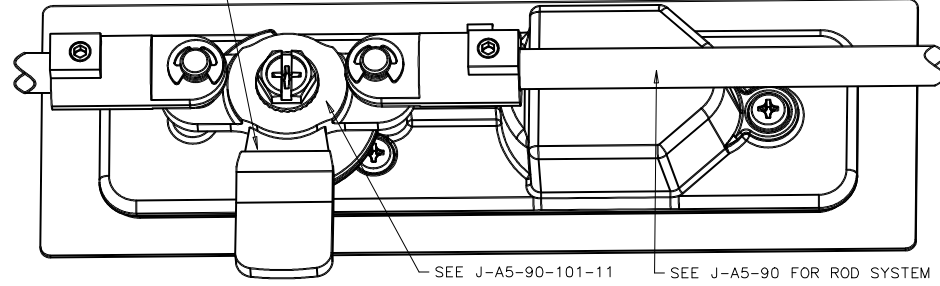

H3-50-303-1XX SHOWN WITH OPTIONAL A5-90-101-11 MULTI POINT ADAPTER PLATE ASSEMBLY

SEE J-A5-90-101-11

SEE J-A5-90 FOR ROD SYSTEM

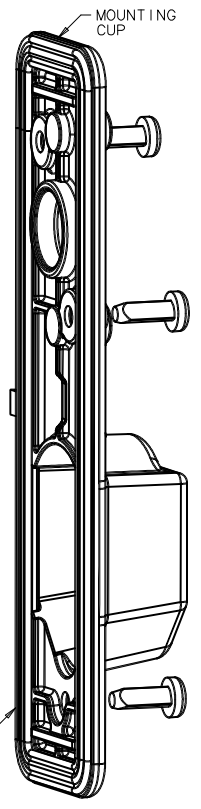
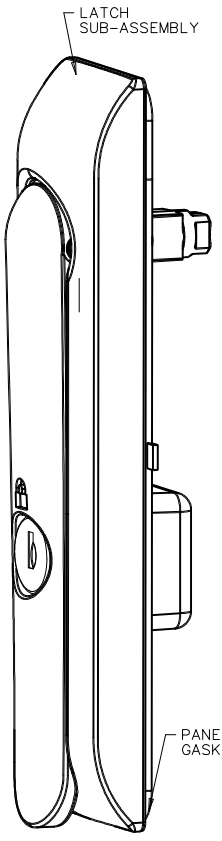

H3-50-303-1XX LATCH SHOWN  
 SEE SHEET 2 FOR VIEWS OF DIN AND TOOL ACCESS VERSIONS

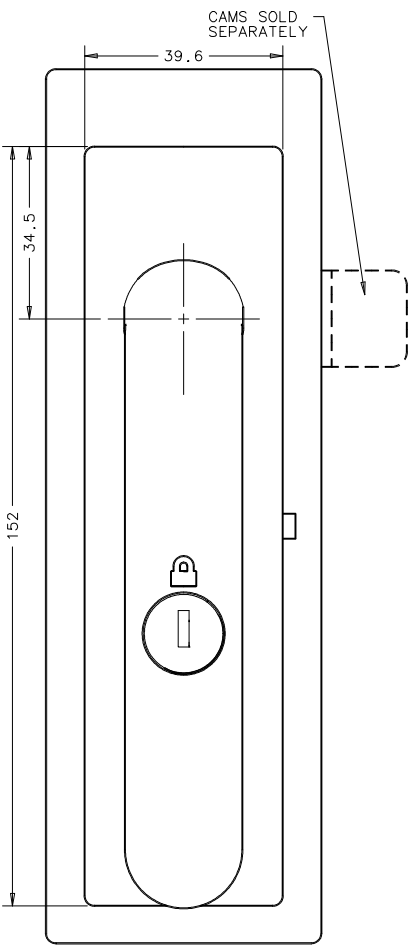

H3-50-303-1XX LATCH SHOWN

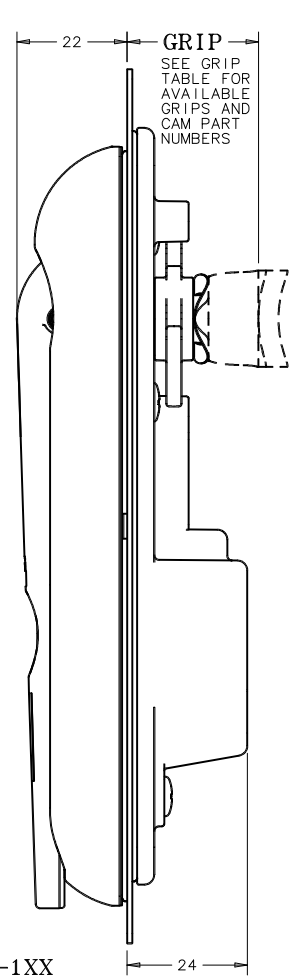

GRIP  
 SEE GRIP TABLE FOR AVAILABLE GRIPS AND CAM PART NUMBERS

**Proprietary Item - Every user expressly granted in writing information disclosed hereon is confidential and all rights patent and otherwise are reserved by Southco, Inc.**

**SWINGHANDLE LATCH, ACTUATOR, OUTDOOR, 25x125 SIZE**

DRAWING NUMBER: J-H3-50-301-1  
MILLIMETERS

ALL DIMENSIONS WITHOUT TOLERANCES ARE FOR REFERENCE ONLY.

A3 PAPER SIZE  
THIRD ANGLE PROJECTION

SHEET 2 OF 2

REV	DATE	DESCRIPTION	MATERIAL	FINISH/COLOR	DESCRIPTION	MATERIAL	FINISH/COLOR
A	03NOV2008	IR/DLH RELEASED FOR PRODUCTION			HANDLE COVER		
B	25NOV2008	IR/ACH PRN: P2008-1345		BLACK POWDERCOAT	DISC SPRING		
C	04 FEB 09	IR/ACH PRN: P2009-0162			DUMMY CAM		
D	22SEP2014	CMS/BGL PRN: P2014-1872	ZAMAC 3	NATURAL	CAM SCREW		
E	05AUG2016	CMS/SJR PRN: P2016-1835			M4x7 SCREWS		
F	09OCT2018	CMS/CDW PRN: P2018-2534			RETAINER		
					HANDLE PIN		
					PAWL SPRING		
					WAVE WASHER		
					PADLOCK HASP		
					SHAFT O-RING		
					SCREW O-RINGS		

**PANEL PREPARATION**

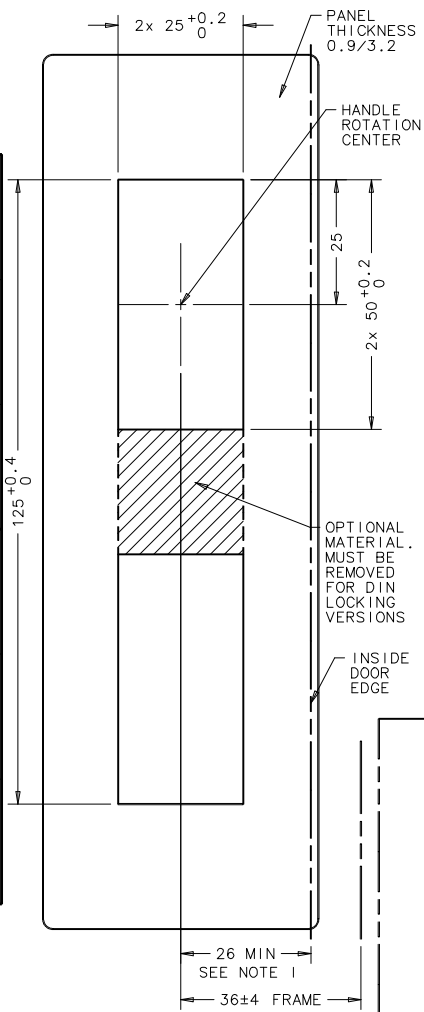

**NOTES:**

- ALL LATCH COMPONENTS ARE RoHS COMPLIANT.
- LATCH INSTALLATION:
  - PREPARE A BURR FREE PANEL OPENING AS SHOWN.
  - INSTALL LATCH SUB-ASSEMBLY FROM THE FRONT SIDE OF THE PANEL AND HOLD IN PLACE.
  - SLIDE THE MOUNTING CUP ONTO THE HANDLE SHAFT.
  - SECURE THE CUP IN PLACE WITH THE THREE M4x0.7x12 SCREWS PROVIDED. MAX SCREW TORQUE 1.5 N-m.
  - PLACE THE ROTATION LIMITER ONTO THE HANDLE SHAFT. THE ROTATION LIMITER ALSO SETS THE ROTATION DIRECTION OF THE LATCH. TO FLIP ACTUATION DIRECTION, SIMPLY REMOVE THE ROTATION ACTUATION LIMITER FROM THE SHAFT, ROTATE IT 90°, AND PLACE BACK ONTO SHAFT.
  - PLACE SHAFT WAVE WASHER ONTO HANDLE SHAFT AGAINST THE TOP OF THE ROTATION LIMITER, FOLLOWED BY THE CAM, THEN THE ACTUATOR PLATE ASSEMBLY IF USED. SECURE EVERYTHING TO SHAFT USING M6x1x14 SCREW. MAX SCREW TORQUE 2.0 N-m.
  - CYCLE THE LATCH FROM OPEN TO CLOSE TO MAKE SURE EVERYTHING MOVES FREELY.
  - FOR TWO POINT LATCHING (NO CENTER LATCHING), A 'DUMMY CAM' MUST BE USED TO MAINTAIN PROPER ASSEMBLY SPACING.
  - IF USED WITH SOUTHCO A5-90-101-11 ADAPTER PLATE ASSEMBLY.
- COSMETIC SPECIFICATION: ALL POWDERCOATED AND CHROME PLATED SURFACES, UNLESS OTHERWISE NOTED, ARE TO CONFORM TO A CLASS 'B' DESIGNATION. ALL OTHER SURFACES, UNLESS OTHERWISE NOTED, ARE TO CONFORM TO A CLASS 'C' DESIGNATION AS DESCRIBED IN SOUTHCO COSMETIC SPECIFICATIONS:
  - S-121-01 FOR CHROME PLATING
  - S-121-02 FOR ZINC PLATING
  - S-121-04 FOR POWDER COATING
  - S-121-05 FOR STAINLESS STEEL PARTS

**PROPER CAM & LIMITER INSTALLATION FOR ROTATING HANDLE CCW TO OPEN**

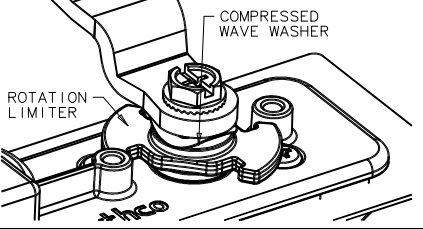

**HARDWARE PACK**

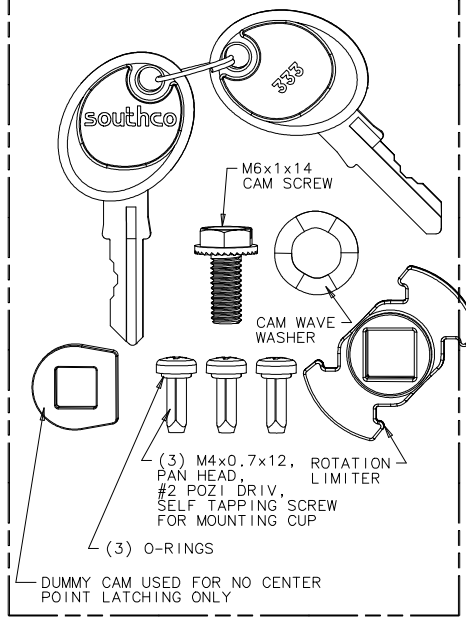

**H3-50-423-1XX  
333 DIN**

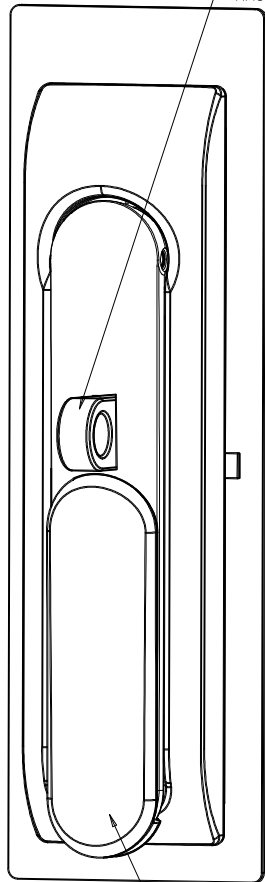

**H3-50-442-1XX  
BELLCORE/  
TELCORDIA 216**

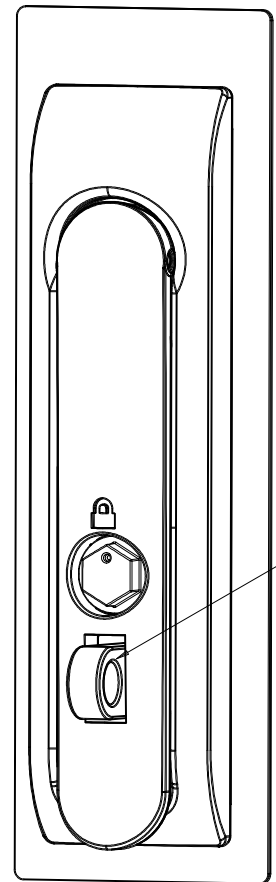

**PROPER CAM, A5 ACTUATOR PLATE, & LIMITER INSTALLATION FOR ROTATING HANDLE CCW TO OPEN**

