

NOTES:

A. CABLE
 UL 2464 [24AWG(7/0.20 TC)*5C]*1C,
 UNSHIELDED, -30 TO 105°C
 BLACK PVC JACKET

B. WIRE DESIGNATION TABLE

WIRE COLOR	J1
BROWN	1
RED	2
ORANGE	3
YELLOW	4
BLACK	6
NOT USED	5

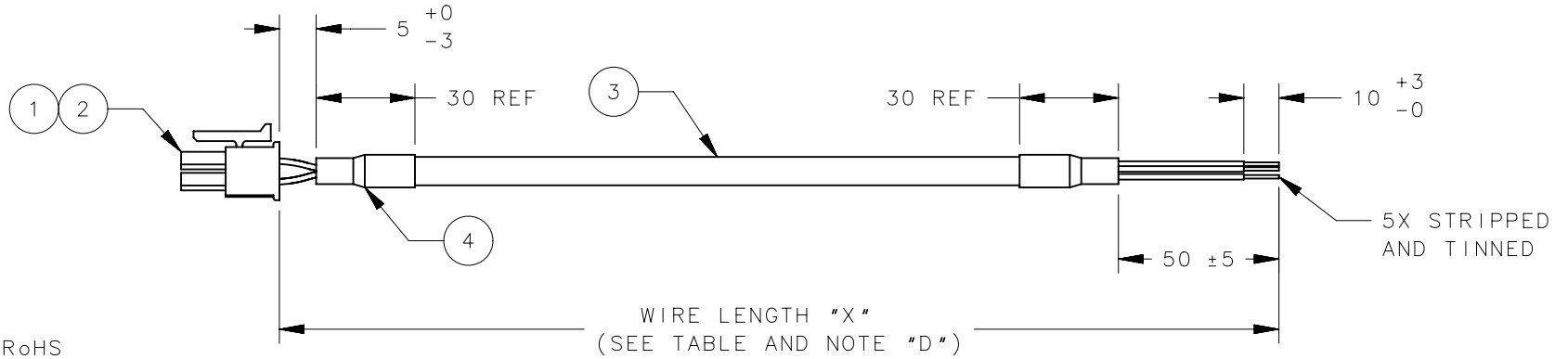

C. MATERIALS COMPLY WITH RoHS DIRECTIVE.

D. LENGTH MEASURED FROM BACK OF CONNECTOR TO BACK OF CONNECTOR.

WIRE LENGTH TABLE		
"X"	LENGTH (mm)	TOLERANCE (mm)
A	250	+25mm-0mm
1	1000	+50mm-0mm
2	2000	+100mm-0mm
3	3000	+100mm-0mm
4	4000	+150mm-0mm
5	5000	+150mm-0mm

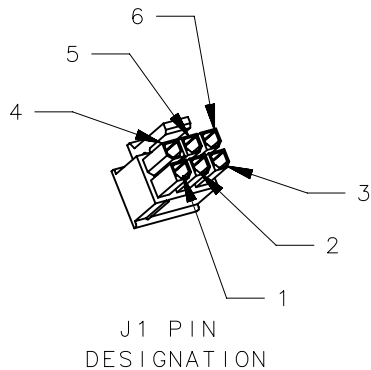

4	HEAT SHRINKABLE TUBING	2	-	BLACK
3	CABLE	-	-	SEE NOTE A
2	CONTACT	5	MOLEX: 43030-0007 (ALT: C3004TB-A1-GU)	-
1	CONNECTOR	1	MOLEX: 43025-0600 (ALT: C3030HF-2X3P)	-
-	ASSEMBLY	1	EA-W21-X00	-
NO.	COMPONENT	QTY	PART NUMBER	SPECIFICATIONS

THIRD ANGLE PROJECTION		 CONNECT • CREATE • INNOVATE	
MILLIMETERS [IN]			
TOLERANCES UNLESS OTHERWISE NOTED		DESCRIPTION	
ALL DIMENSIONS WITHOUT TOLERANCES ARE FOR REFERENCE ONLY.		WIRE HARNESS	
PROPRIETARY ITEM <small>EXCEPT FOR USES EXPRESSLY GRANTED IN WRITING, INFORMATION DISCLOSED HEREON IS CONFIDENTIAL AND ALL RIGHTS, PATENT AND OTHERWISE, ARE RESERVED BY SOUTHCO, INC.</small>		SIZE A4	SYSTEM NX
PER ASME Y14.5M-1994		DWG NO. J-EA-W21-X00	DRAWN BY BDT/KAM
		DATE 29JUN2015	SCALE 1:1
		SHEET 1 OF 1	