



82 DZUS® Performance Quarter-Turn Fasteners Studs

Material and Finish

Studs: Steel, zinc plated and chromate or stainless steel
 Bail cover: ABS, black

Accessories

Tool head recess key:
 Part number: 29-90-214-10

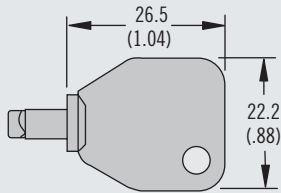

H Head Styles - Tool Actuated

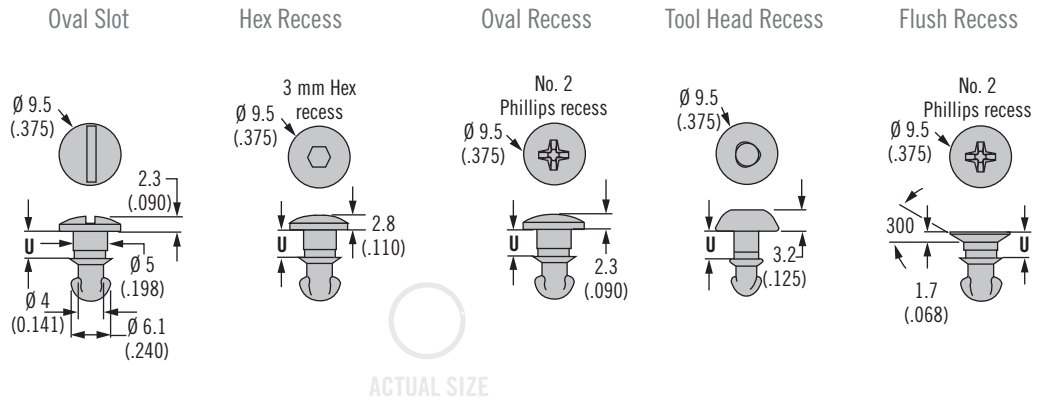

H Head Styles - Hand Actuated

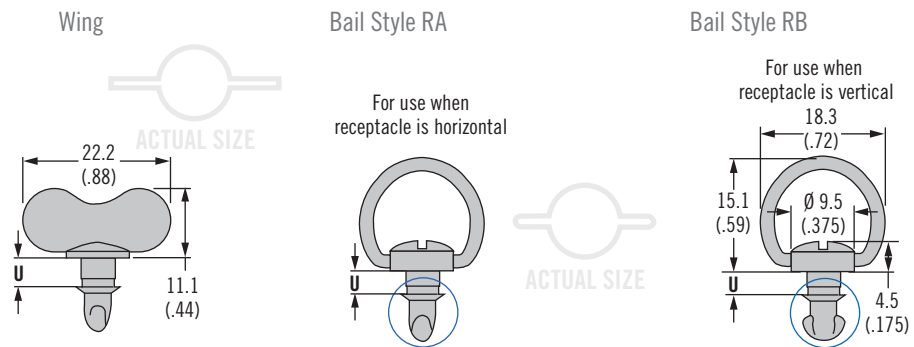

Optional Bail Cover

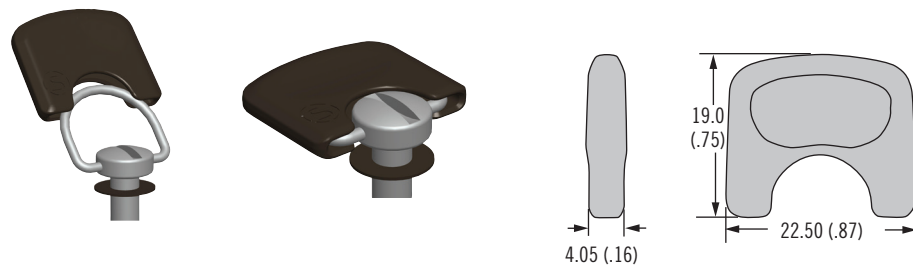

Bail Cover Part Number
82-2-B-000

Installation Notes

Bail cover:
 A retainer must be fitted under the stud head to fit flush with surface
 Retainer part number 82-32-301-12 (see page 443)

Stud Panel Preparation

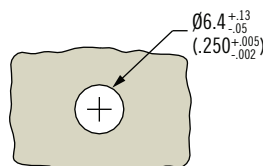

Flush Head Styles

(when outer panel is 1.3 (.050) or greater)

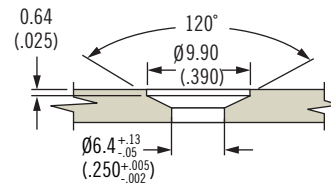

82 DZUS® Lion Quarter-Turn Fasteners

Stud selection



- H** Head style
- 11 Oval slot
 - 12 Wing head
 - 15 Bail RA
 - 16 Bail RB
 - 19 Oval Phillips recess
 - 28 Flush Phillips recess
 - 78 Hex recess
 - T Tool head recess
(not available in stainless steel)

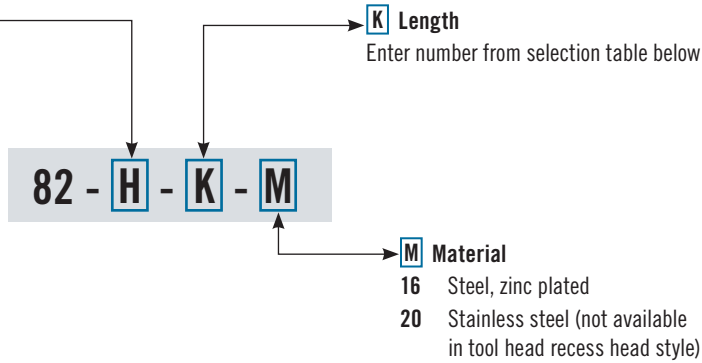

Part Number Selection

82

85

D8

D9

D1

D4

D5

D7

NY



To select correct fastener:

1. Select receptacle

Choose a receptacle from pages 438-442

2. Select retainer and accessories

from page 443 and note any adjustment values

3. Specify stud length

Calculate the total material thickness (TMT) using the formula given for the receptacle selected. Find the range of TMT using the stud length selection table (left) using the column (A, B, C, or D) given for the receptacle selected, find **K**

4. Complete the stud part number

by specifying the head style **H**, stud length **K**, and material **M**

Example:

For rivet-on with base receptacle 82-35-302-15 use column D

For TMT value calculated as 5.2 (.206), K = 200

For slotted head style in steel material, completed part number: 82-11-200-16

A complete example can be found on page 435

Notes

Stainless steel material may require a higher minimum order quantity. Contact Southco for details.

Stud Length Table									
A		B		C		D		K	U
TMT Range For: 82-35-306-10		TMT Range For: 82-35-308-55 82-35-310-55		TMT Range For: 82-35-315-55		TMT Range For: All Other Receptacles			
Min.	Max.	Min.	Max.	Min.	Max.	Min.	Max.		
0.7 (.026)	1.2 (.045)	~	~	~	~	2.3 (.090)	2.8 (.110)	100	3.2 (.127)
1.2 (.045)	1.7 (.065)	~	~	~	~	2.8 (.110)	3.3 (.130)	120	3.7 (.147)
1.7 (.065)	2.2 (.085)	~	~	~	~	3.3 (.130)	3.8 (.150)	140	4.2 (.167)
2.2 (.085)	2.7 (.105)	0 (0)	0.5 (.019)	1.3 (.050)	1.8 (.070)	3.8 (.150)	4.3 (.170)	160	4.7 (.187)
2.7 (.105)	3.2 (.125)	0.5 (.019)	1 (.039)	1.8 (.070)	2.3 (.090)	4.3 (.170)	4.8 (.190)	180	5.3 (.207)
3.2 (.125)	3.7 (.145)	1 (.039)	1.5 (.059)	2.3 (.090)	2.8 (.110)	4.8 (.190)	5.3 (.210)	200	5.8 (.227)
3.7 (.145)	4.2 (.165)	1.5 (.059)	2 (.079)	2.8 (.110)	3.3 (.130)	5.3 (.210)	5.8 (.230)	220	6.3 (.247)
4.2 (.165)	4.7 (.185)	2 (.079)	2.5 (.099)	3.3 (.130)	3.8 (.150)	5.8 (.230)	6.3 (.250)	240	6.8 (.267)
4.7 (.185)	5.2 (.205)	2.5 (.099)	3 (.119)	3.8 (.150)	4.3 (.170)	6.4 (.250)	6.9 (.270)	260	7.3 (.287)
5.2 (.205)	5.7 (.225)	3 (.119)	3.5 (.139)	4.3 (.170)	4.8 (.190)	6.9 (.270)	7.4 (.290)	280	7.8 (.307)
5.7 (.225)	6.2 (.245)	3.5 (.139)	4.1 (.159)	4.8 (.190)	5.3 (.210)	7.4 (.290)	7.9 (.310)	300	8.3 (.327)
~	~	4.1 (.159)	4.6 (.179)	5.3 (.210)	5.8 (.230)	7.9 (.310)	8.4 (.330)	320	8.8 (.347)
~	~	4.6 (.179)	5.1 (.199)	5.8 (.230)	6.3 (.250)	8.4 (.330)	8.9 (.350)	340	9.3 (.367)
~	~	5.1 (.199)	5.6 (.219)	6.3 (.250)	6.8 (.270)	8.9 (.350)	9.4 (.370)	360	9.8 (.387)
~	~	5.6 (.219)	6.1 (.239)	6.8 (.270)	7.3 (.290)	9.4 (.370)	9.9 (.390)	380	10.3 (.407)
~	~	6.1 (.239)	6.6 (.259)	7.3 (.290)	7.8 (.310)	9.9 (.390)	10.4 (.410)	400	10.8 (.427)
~	~	6.6 (.259)	7.1 (.279)	7.8 (.310)	8.3 (.330)	10.4 (.410)	10.9 (.430)	420	11.4 (.447)
~	~	7.1 (.279)	7.6 (.299)	8.3 (.330)	8.8 (.350)	10.9 (.430)	11.4 (.450)	440	11.9 (.467)
~	~	7.6 (.299)	8.1 (.319)	8.8 (.350)	9.3 (.370)	11.4 (.450)	11.9 (.470)	460	12.4 (.487)
~	~	8.1 (.319)	8.6 (.339)	9.3 (.370)	9.8 (.390)	11.9 (.470)	12.4 (.490)	480	12.9 (.507)
~	~	8.6 (.339)	9.1 (.359)	9.8 (.390)	10.3 (.410)	12.5 (.490)	12.9 (.510)	500	13.4 (.527)
~	~	9.1 (.359)	9.6 (.379)	10.3 (.410)	10.8 (.430)	13 (.510)	13.5 (.530)	520	13.9 (.547)
~	~	9.6 (.379)	10.1 (.399)	10.8 (.430)	11.3 (.450)	13.5 (.530)	14 (.550)	540	14.4 (.567)
~	~	10.1 (.399)	10.6 (.419)	11.3 (.450)	11.8 (.470)	14 (.550)	14.5 (.570)	560	14.9 (.587)
~	~	10.6 (.419)	11.1 (.439)	11.8 (.470)	12.3 (.490)	14.5 (.570)	15 (.590)	580	15.4 (.607)



82 DZUS[®] Lion Quarter-Turn Fasteners Receptacles

Material and Finish

Steel, zinc immersion coating

Installation Notes

Install with $\varnothing 2.5$ (3/32) rivets, spring plate must float freely after riveting

Part Number

See table

Notes

Utilize stud selection column indicated when choosing a stud length from the stud length table on page 437

Rivet-On With Base

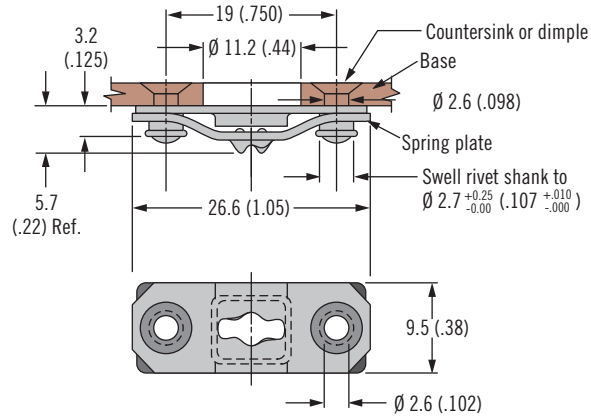

ACTUAL SIZE

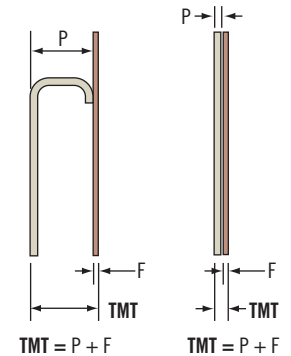

Part Number	Stud Selection Column
82-35-302-15	D

Material and Finish

Steel, zinc immersion coating or stainless steel

Installation Notes

Install with $\varnothing 2.5$ (3/32) rivets, spring plate must float freely after riveting

Part Number

See table

Notes

Utilize stud selection column indicated when choosing a stud length from the stud length table on page 437

Rivet-On Without Base

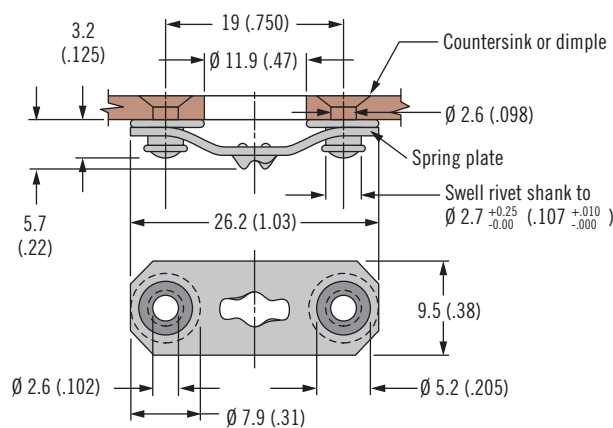

ACTUAL SIZE

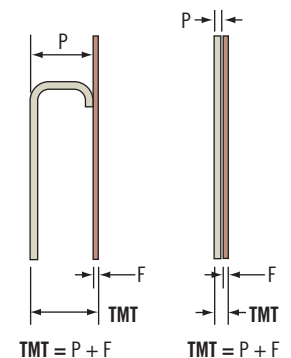

Material	Part Number	Stud Selection Column
Steel	82-35-295-15	D
Stainless steel	82-35-295-20	

82 DZUS® Lion Quarter-Turn Fasteners Receptacles



Weld-On

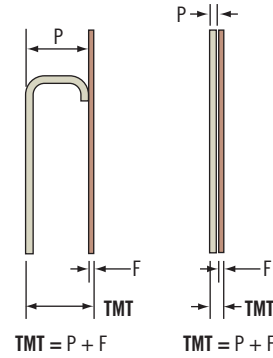
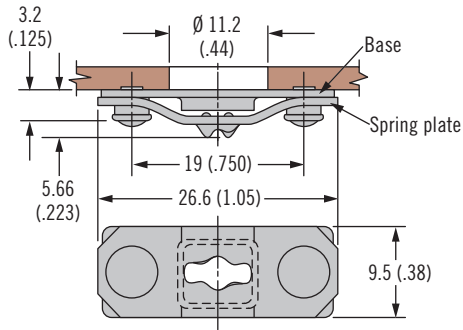

ACTUAL SIZE

Part Number	Stud Selection Column
82-35-303-15	D

Material and Finish

Steel, zinc immersion coating

Installation Notes

Spring plate must float freely after welding

Part Number

See table

Notes

Utilize stud selection column indicated when choosing a stud length from the stud length table on page 437

82

85

D8

D9

D1

D4

D5

D7

NY



Side Mount

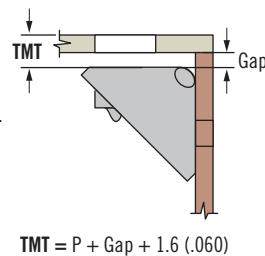
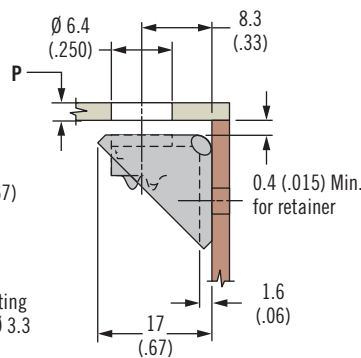
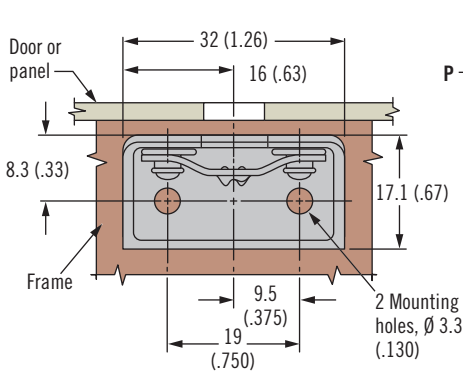

ACTUAL SIZE

Part Number	Stud Selection Column
82-45-101-15	D

Material and Finish

Steel, zinc immersion coating

Installation Notes

Install with Ø 2.5 (3/32) rivets

Part Number

See table

Notes

Utilize stud selection column indicated when choosing a stud length from the stud length table on page 437

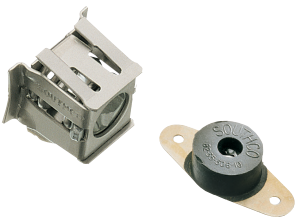

82 DZUS[®] Lion Quarter-Turn Fasteners Receptacles

Material and Finish

Steel, zinc plated and neoprene

Installation Notes

Install with \varnothing 2.5 (3/32) rivets

82

85

D8

D9

D1

D4

D5

D7

NY

Part Number

See table

Notes

Utilize stud selection column indicated when choosing a stud length from the stud length table on page 437

Vibration Isolating

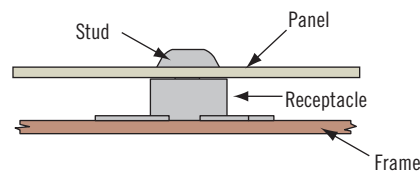
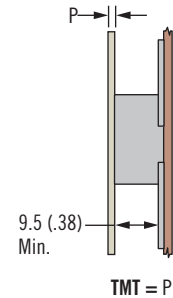
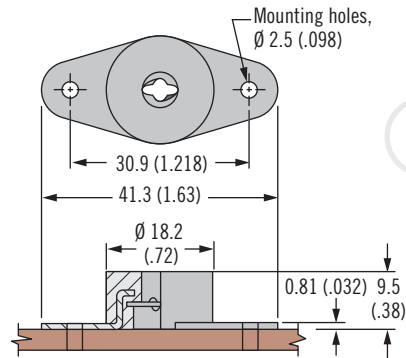

Part Number	Stud Selection Column
82-35-306-10	A

Material and Finish

Steel, zinc plated and stainless steel

Installation Notes

Installation Tool

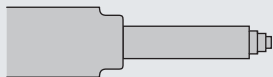

Part Number: 29-8125-309

Snap-In - Front Mount

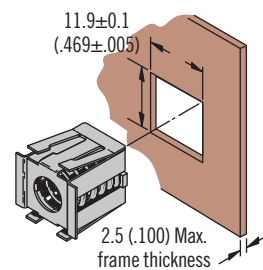
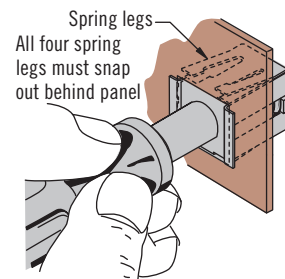
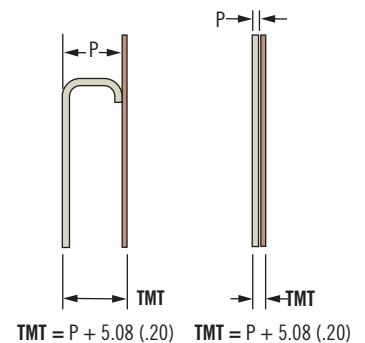
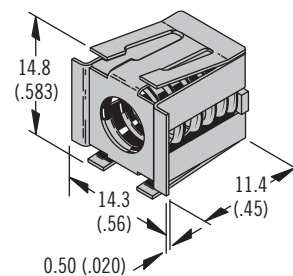

Part Number

See table

Notes

Utilize stud selection column indicated when choosing a stud length from the stud length table on page 437

Part Number	Stud Selection Column
82-35-309-56	D

82 DZUS® Lion Quarter-Turn Fasteners Receptacles

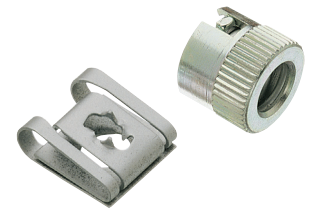

Clip-On

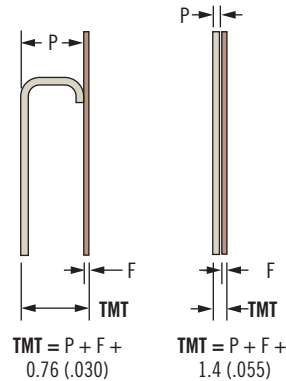
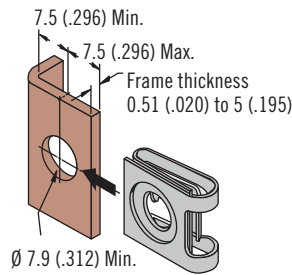
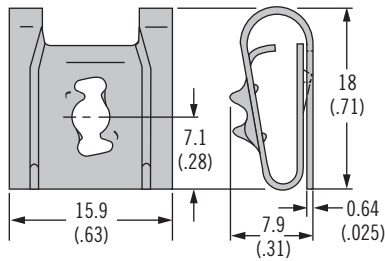

By Hand

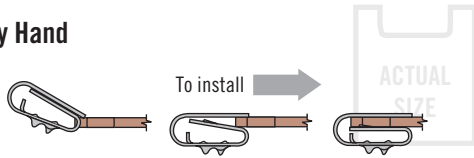

With Screwdriver

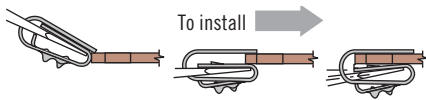

Material	Part Number	Stud Selection Column
Steel	82-47-113-15	D
Stainless steel	82-47-113-20	

Material and Finish

Steel, zinc immersion coating or stainless steel

Part Number

See table

Notes

Utilize stud selection column indicated when choosing a stud length from the stud length table on page 437

Press-In

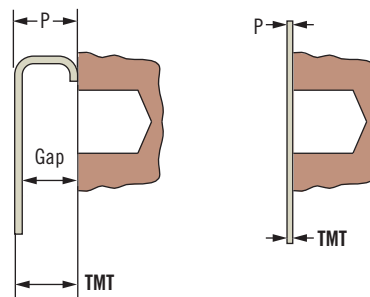
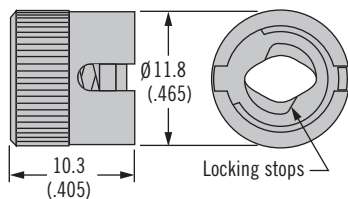

$$TMT = P + \text{Gap} - 0.5 (.020)$$

(when gap is > retainer thickness)

$$TMT = P + (\text{Retainer adjustment value}) - 0.5 (.020)$$

Solid Install

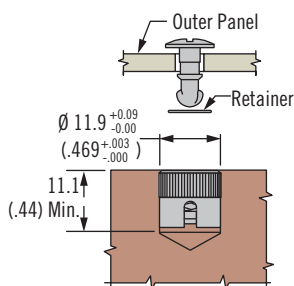

Blind Install

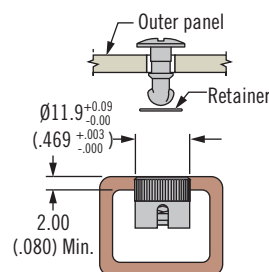

Part Number	Stud Selection Column
82-35-308-55	B

Material and Finish

Steel, zinc plated and stainless steel

Installation Notes

Press receptacle flush to frame

Notes

Receptacle shown installed flush to the frame. To eliminate the gap between the frame and outer panel, install to a depth \geq the thickness of the selected retainer. This depth should be added to the TMT.

Part Number

See table

Notes

Utilize stud selection column indicated when choosing a stud length from the stud length table on page 437

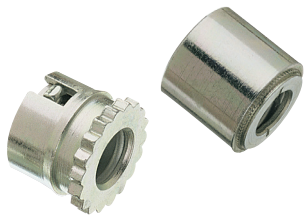

82 DZUS® Lion Quarter-Turn Fasteners

Receptacles · Self-clinching

Material and Finish

Steel, zinc plated and stainless steel

82

Installation Notes

Press receptacle flush to frame

85

D8

Notes

Receptacle shown installed flush to the frame. To eliminate the gap between the frame and outer panel, install to a depth \geq the thickness of the selected retainer. This depth should be added to the TMT.

D9

D1

D4

D5

Part Number

See table

D7

NY

Notes

Utilize stud selection column indicated when choosing a stud length from the stud length table on page 437



Ultrasonic For Thermoplastics

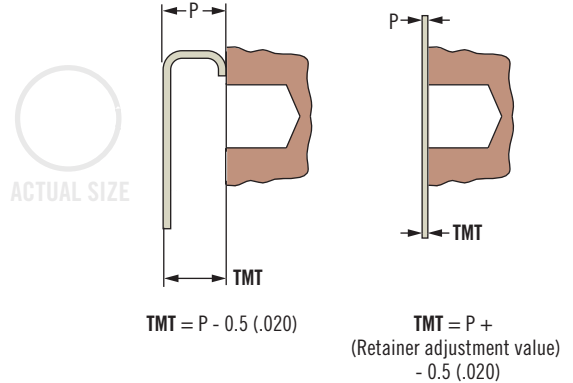
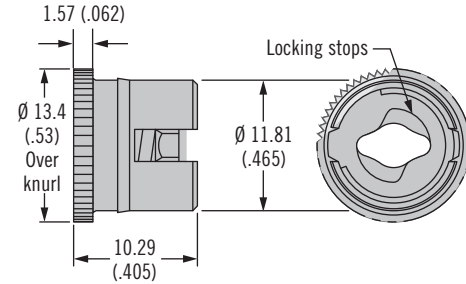

Installation

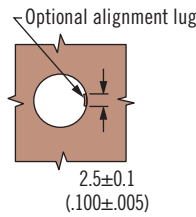

Blind Hole Installation

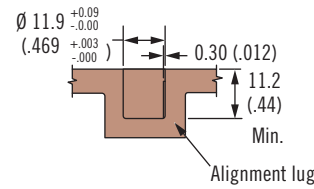

Thru Hole Installation

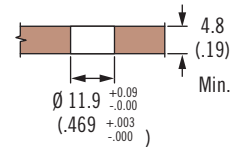

Part Number	Stud Selection Column
82-35-310-55	B

Material and Finish

Steel, zinc plated and stainless steel

Installation Notes

For use in low carbon steels, aluminum and stainless steels in the annealed condition that are RB85 or softer

See page 627 for installation guidelines

Part Number

See table

Notes

Utilize stud selection column indicated when choosing a stud length from the stud length table on page 437

Shielded – Self-Clinching

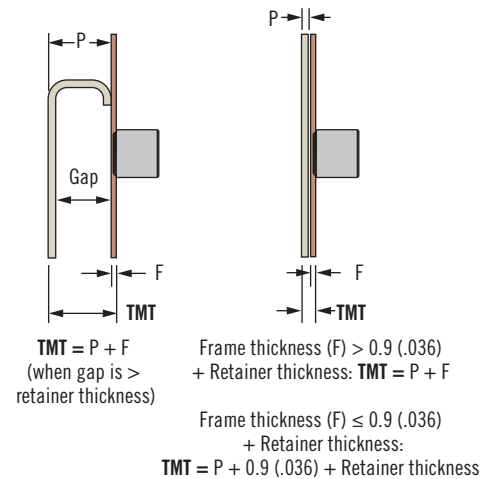
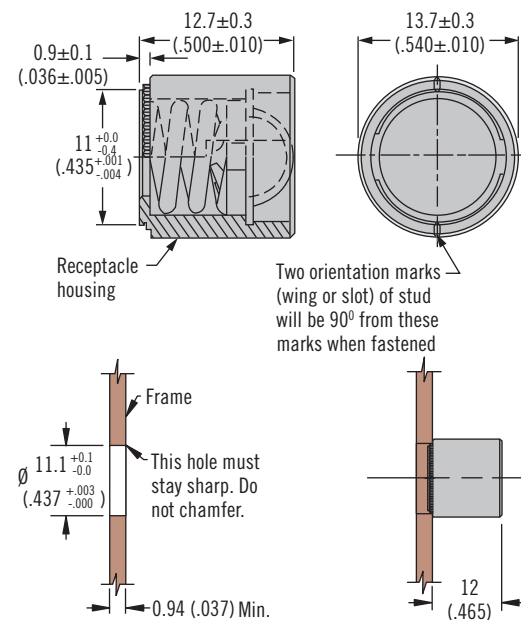

Part Number	Stud Selection Column
82-35-315-55	C

82 DZUS® Lion Quarter-Turn Fasteners

Retainers · Accessories

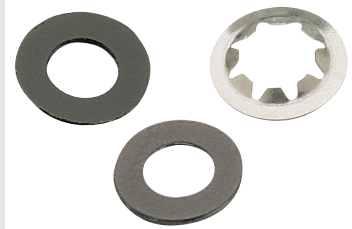

Retainer Push-On

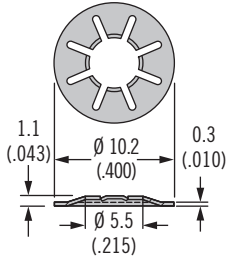

Retainer Push-On Plastic

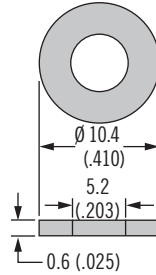

Retainer Split

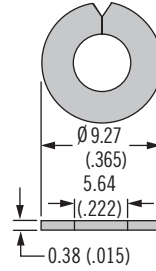

Sealing Washer

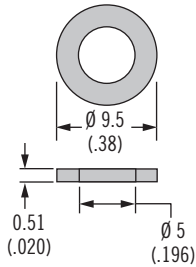

Ejector Spring

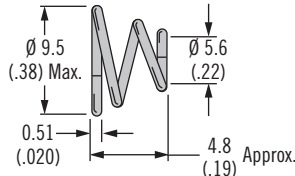

Cupped Washer

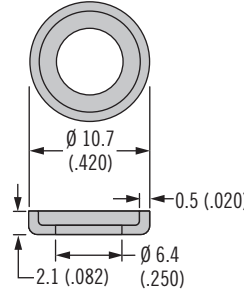

Flat Wear Washer

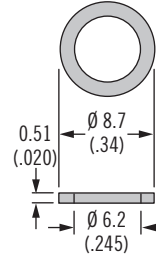

Snap-In Retainer

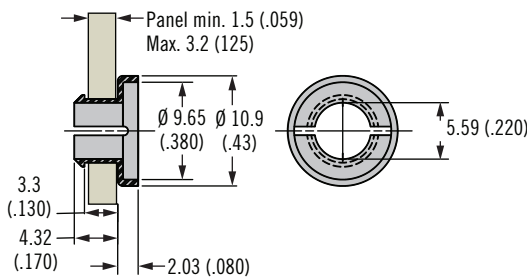

Material and Finish

See table

Installation Notes

For standard retainers:

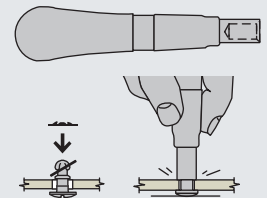

Part Number: 82-0-22542-11

For split retainers:

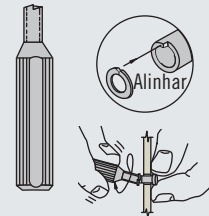

Part Number: 82-0-7595-11

Notes

For snap-in retainer:

Min. stud **K** = 180 when using snap-in retainer (see page 437 for **K** reference).

Install stud into retainer before inserting into panel

Type	Part Number	Material	Adjustment Value
Push-on retainer	82-32-201-20	Stainless steel	Add 0.25 (.010)
Push-on plastic retainer	82-32-301-12	Nylon, black	Add 0.64 (.025)
Split retainer	82-32-101-20	Stainless steel	Add 0.38 (.015)
Sealing washer	82-43-201-38	Neoprene nitrile rubber, black	Add 0.51 (.020)
Ejector spring	43-13-1-24	Stainless steel	Add 0.51 (.020)
Cupped washer	82-46-101-39	Nylon, white	Add 0.51 (.020)
	82-46-101-41	Nylon, black	
Flat wear washer	82-46-103-39	Nylon, white	Add 0.51 (.020)
Snap-in retainer	82-32-401-41	Nylon, black	Add 0.51 (.020)

Part Number

See table

Notes

Adjustment value:

When using accessories the components increase TMT

Add the adjustment value to your outer panel thickness (P) when calculating TMT (see page 435 for example)

82
85
D8
D9
D1
D4
D5
D7
NY
↓
↙ ↘



85 DZUS® Lion Quarter-Turn Fasteners Studs

Material and Finish

Studs: Steel, zinc plated or stainless steel
 Bail cover: ABS, black

Accessories

Tool head recess key:
 Part number: 29-90-215-10

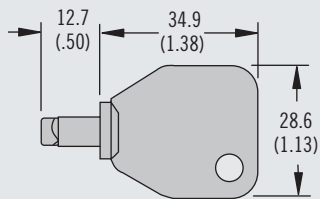

H Head Styles - Tool Actuated

Oval Slot

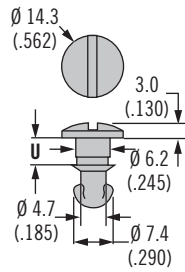

Hex Recess

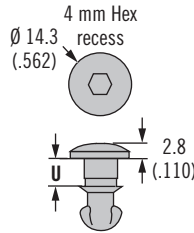

Phillips Recess

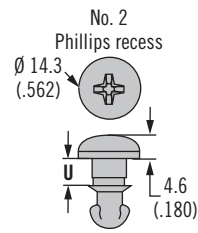

Tool Head Recess

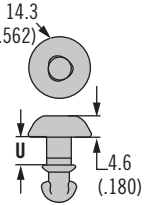

H Head Styles - Hand Actuated

Wing

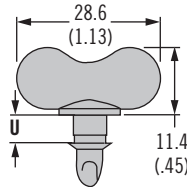
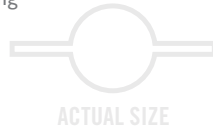

Bail Style RA

For use when receptacle is horizontal

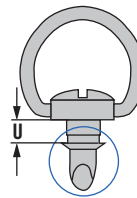

Bail Style RB

For use when receptacle is vertical

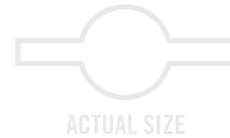
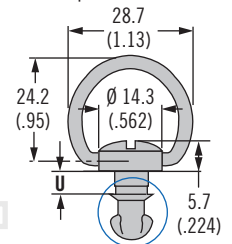

Installation Notes

Bail cover:
 A wear washer must be fitted under the stud head to fit flush with surface

Wear washer part number
 85-34-301-12 (see page 449)

Optional Bail Cover

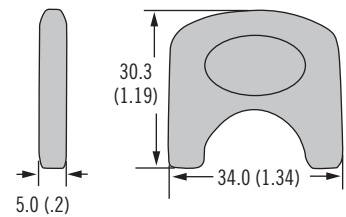
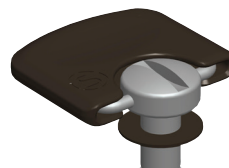

Bail Cover Part Number
85-5-B-000

Stud Panel Preparation

Prepare Hole

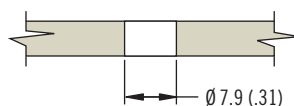

85 DZUS® Lion Quarter-Turn Fasteners

Stud selection



- H** Head style
- 11 Oval slot
 - 12 Wing head
 - 15 Bail RA
 - 16 Bail RB
 - 78 Hex recess
 - P Oval Phillips recess
 - T Tool head recess (not available in stainless steel)

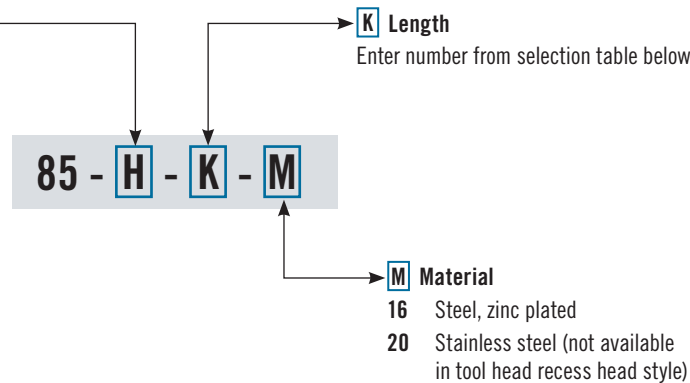

Stud Length Table							
A		B		C		K	U
TMT Range For: 85-35-308-55		TMT Range For: 85-35-311-55		TMT Range For: All other receptacles			
Min.	Max.	Min.	Max.	Min.	Max.		
~	~	~	~	2.3 (.090)	2.8 (.110)	100	5.2 (.205)
~	~	~	~	2.8 (.110)	3.3 (.130)	120	5.7 (.225)
~	~	~	~	3.3 (.130)	3.8 (.150)	140	6.2 (.245)
~	~	~	~	3.8 (.150)	4.3 (.170)	160	6.7 (.265)
~	~	~	~	4.3 (.170)	4.8 (.190)	180	7.2 (.285)
~	~	~	~	4.8 (.190)	5.3 (.210)	200	7.7 (.305)
~	~	~	~	5.3 (.210)	5.8 (.230)	220	8.3 (.325)
~	~	1.3 (.050)	1.8 (.070)	5.8 (.230)	6.3 (.250)	240	8.8 (.345)
0.4 (.015)	0.9 (.035)	1.8 (.070)	2.3 (.090)	6.4 (.250)	6.9 (.270)	260	9.3 (.365)
0.9 (.035)	1.4 (.055)	2.3 (.090)	2.8 (.110)	6.9 (.270)	7.4 (.290)	280	9.8 (.385)
1.4 (.055)	1.9 (.075)	2.8 (.110)	3.3 (.130)	7.4 (.290)	7.9 (.310)	300	10.3 (.405)
1.9 (.075)	2.4 (.095)	3.3 (.130)	3.8 (.150)	7.9 (.310)	8.4 (.330)	320	10.8 (.425)
2.4 (.095)	2.9 (.115)	3.8 (.150)	4.3 (.170)	8.4 (.330)	8.9 (.350)	340	11.3 (.445)
2.9 (.115)	3.4 (.135)	4.3 (.170)	4.8 (.190)	8.9 (.350)	9.4 (.370)	360	11.8 (.465)
3.4 (.135)	3.9 (.155)	4.8 (.190)	5.3 (.210)	9.4 (.370)	9.9 (.390)	380	12.3 (.485)
3.9 (.155)	4.4 (.175)	5.3 (.210)	5.8 (.230)	9.9 (.390)	10.4 (.410)	400	12.8 (.505)
4.4 (.175)	4.9 (.195)	5.8 (.230)	6.3 (.250)	10.4 (.410)	10.9 (.430)	420	13.3 (.525)
5 (.195)	5.5 (.215)	6.4 (.250)	6.9 (.270)	10.9 (.430)	11.4 (.450)	440	13.8 (.545)
5.5 (.215)	6 (.235)	6.9 (.270)	7.4 (.290)	11.4 (.450)	11.9 (.470)	460	14.4 (.565)
6 (.235)	6.5 (.255)	7.4 (.290)	7.9 (.310)	11.9 (.470)	12.4 (.490)	480	14.9 (.585)
6.5 (.255)	7 (.275)	7.9 (.310)	8.4 (.330)	12.5 (.490)	12.9 (.510)	500	15.4 (.605)
7 (.275)	7.5 (.295)	8.4 (.330)	8.9 (.350)	13 (.510)	13.5 (.530)	520	15.9 (.625)
7.5 (.295)	8 (.315)	8.9 (.350)	9.4 (.370)	13.5 (.530)	14 (.550)	540	16.4 (.645)
8 (.315)	8.5 (.335)	9.4 (.370)	9.9 (.390)	14 (.550)	14.5 (.570)	560	16.9 (.665)
8.5 (.335)	9 (.355)	9.9 (.390)	10.4 (.410)	14.5 (.570)	15 (.590)	580	17.4 (.685)

Part Number Selection

To select correct fastener:
1. Select receptacle

Choose a receptacle from page 446-448

2. Select retainer and accessories

from page 449 and note any adjustment values

3. Specify stud length

Calculate the total material thickness (TMT) using the formula given for the receptacle selected. Find the range of TMT using the stud length selection table (left) using the column (A, B or C) given for the receptacle selected, find **K**

4. Complete the stud part number

by specifying the head style **H**, stud length **K**, and material **M**

Example:

For rivet-on with base receptacle 85-35-295-15 use column C

For TMT value calculated as 5.2 (.206), K = 200

For slotted head style in steel material, completed part number: 85-11-200-16

A complete example can be found on page 435

Notes

Stainless steel material may require a higher minimum order quantity. Contact Southco for details.

- 82
- 85**
- D8
- D9
- D1
- D4
- D5
- D7
- NY

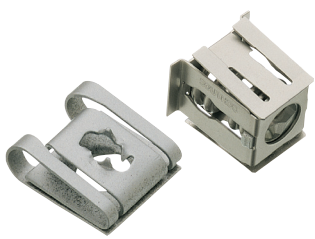

85 DZUS® Lion Quarter-Turn Fasteners Receptacles

Material and Finish

Steel, zinc immersion coating or stainless steel

82

85

D8

D9

D1

D4

D5

D7

NY

Part Number

See table

Notes

Utilize stud selection column indicated when choosing a stud length from the stud length table on page 445

Clip-On

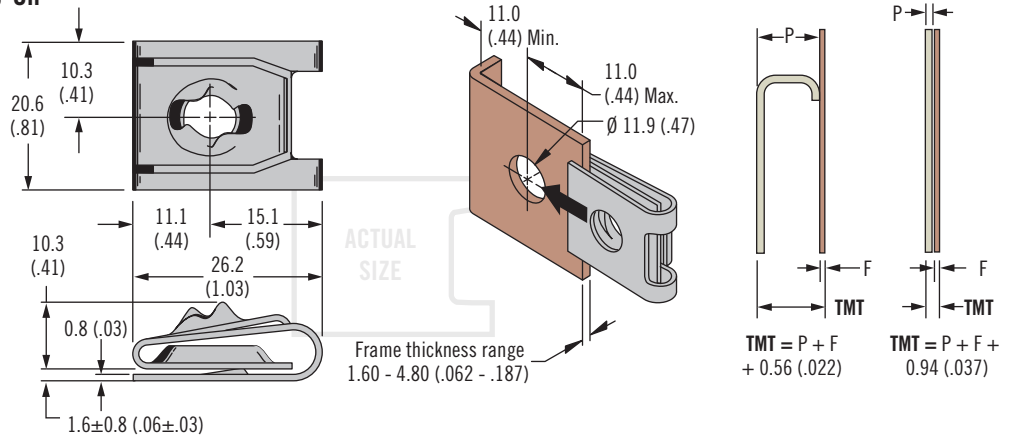

By Hand



With Screwdriver



Material	Part Number	Stud Selection Column
Steel	85-47-101-15	C
Stainless steel	85-47-101-20	

Material and Finish

Steel, zinc plated and stainless steel

Installation Tool

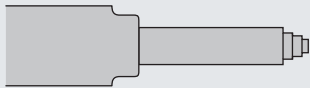

Part Number: 29-8125-309

Snap-In – Front Mount

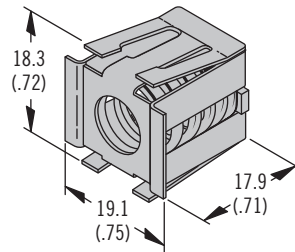

ACTUAL SIZE

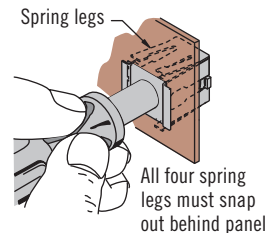
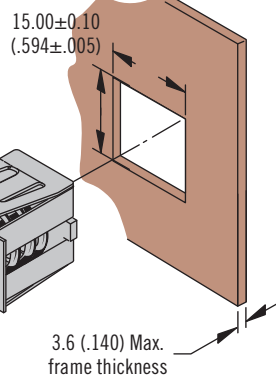
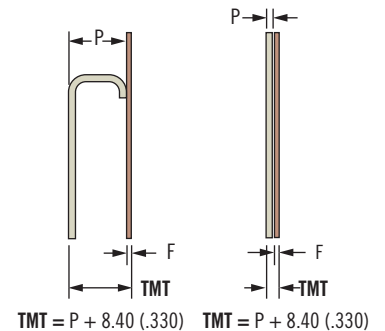

Part Number	Stud Selection Column
85-35-309-56	C

Part Number

See table

Notes

Utilize stud selection column indicated when choosing a stud length from the stud length table on page 445

85 DZUS® Lion Quarter-Turn Fasteners Receptacles



Press-In

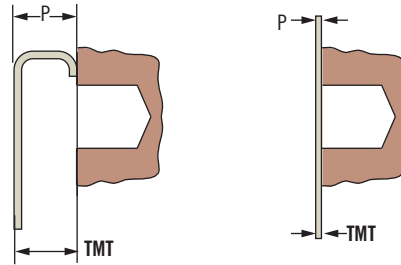
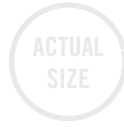
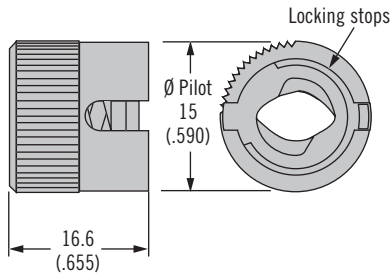

$TMT = P + \text{Gap} - 0.6 (.025)$
(when gap is > retainer thickness)

$TMT = P +$
(Retainer adjustment value)
 $- 0.6 (.025)$

Solid Install

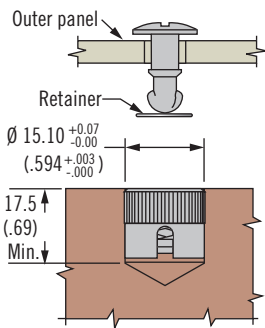

Blind Install

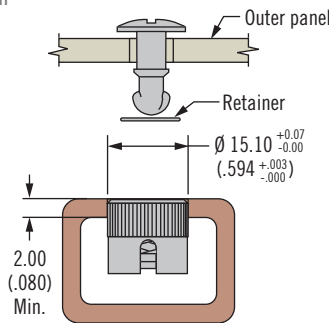

Material and Finish

Steel, zinc plated and stainless steel

Installation Notes

Press receptacle flush to frame

Notes

Receptacle shown installed flush to the frame. To eliminate the gap between the frame and outer panel, install to a depth \geq the thickness of the selected retainer. This depth should be added to the TMT.

Part Number

See table

Notes

Utilize stud selection column indicated when choosing a stud length from the stud length table on page 445

Part Number	Stud Selection Column
85-35-308-55	A

Shielded – Self-Clinching

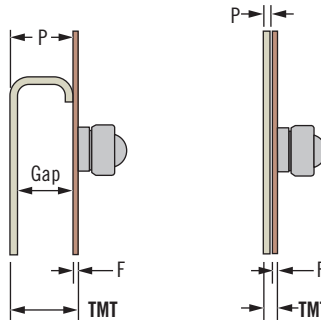
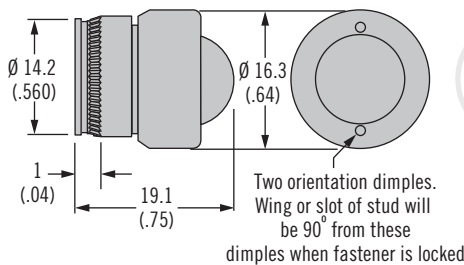

$TMT = P + F$
(when gap is > retainer thickness)

Frame thickness (F) > 0.9 (.036)
+ Retainer thickness: $TMT = P + F$

Frame thickness (F) \geq 0.9 (.036)
+ Retainer thickness:
 $TMT = P + 0.9 (.036) + \text{Retainer thickness}$

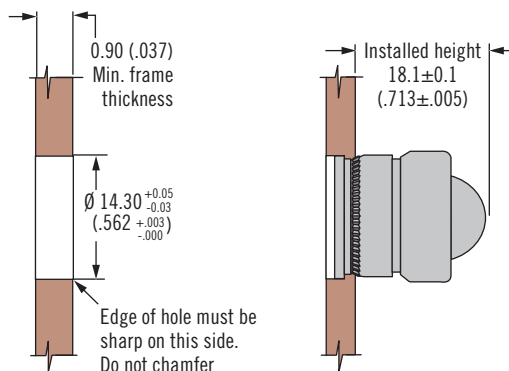

Material and Finish

Steel, zinc plated and stainless steel

Installation Notes

For use in low carbon steels, aluminum and stainless steels in the annealed condition that are R_p85 or softer.

See page 627 for installation guidelines

Installation Tool

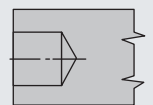

Part number: 90-2825-11

Part Number

See table

Notes

Utilize stud selection column indicated when choosing a stud length from the stud length table on page 445

Part Number	Stud Selection Column
85-35-311-55	B



85 DZUS® Lion Quarter-Turn Fasteners Receptacles

Material and Finish

Steel, zinc immersion coating or stainless steel

82

Installation Notes

Install with $\varnothing 3$ (.125) rivets, spring must float freely after riveting

85

D8

D9

Part Number

See table

D1

Notes

Utilize stud selection column indicated when choosing a stud length from the stud length table on page 445

D4

D5

D7

Rivet-On With Base

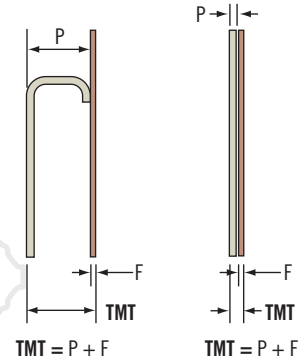
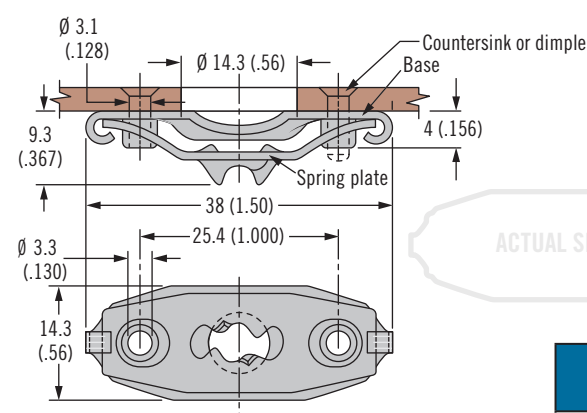

Material	Part Number	Stud Selection Column
Steel	85-35-295-15	C
Stainless steel	85-35-295-20	

Material and Finish

Steel, zinc immersion coating

NY

Installation Notes

Spring must float freely after welding

Part Number

See table

Notes

Utilize stud selection column indicated when choosing a stud length from the stud length table on page 445

Weld-On

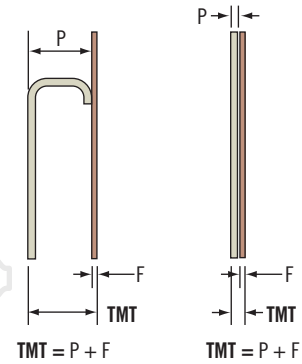
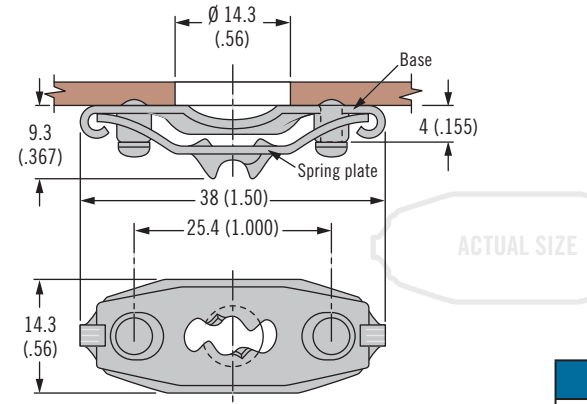

Part Number	Stud Selection Column
85-35-296-15	C

Material and Finish

Steel, zinc immersion coating

Part Number

See table

Notes

Utilize stud selection column indicated when choosing a stud length from the stud length table on page 445

Side Mount

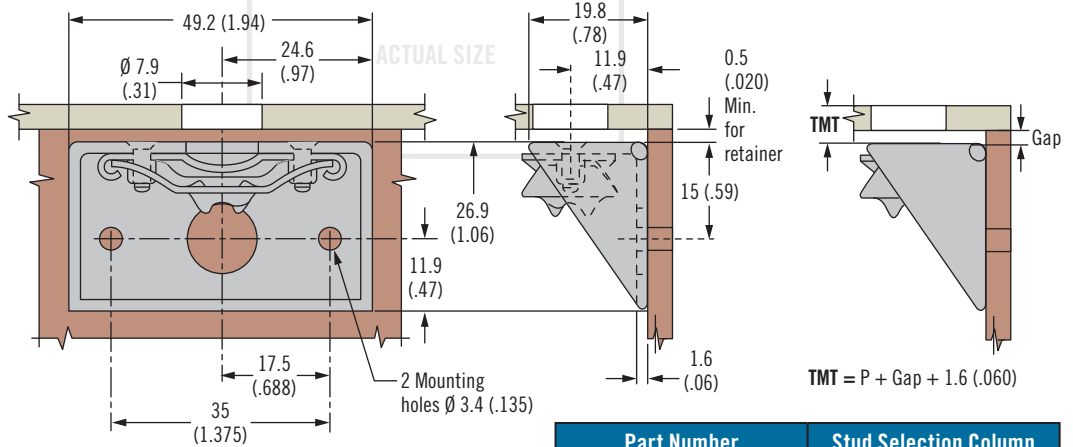

Part Number	Stud Selection Column
85-45-101-15	C

85 DZUS® Lion Quarter-Turn Fasteners

Retainers · Accessories

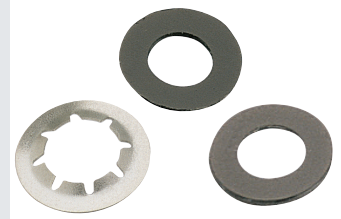

Retainers

Push-On - Stainless Steel

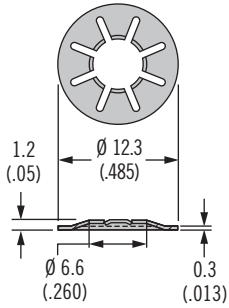

Push-On - Plastic

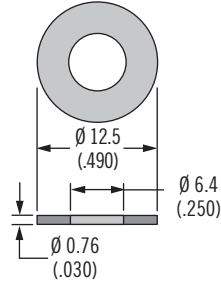

Push-On - Neoprene

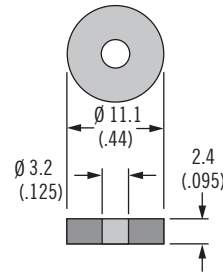

Sealing Washer

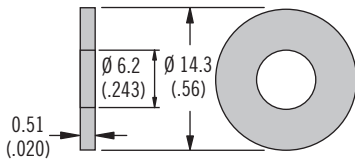

Ejector Spring

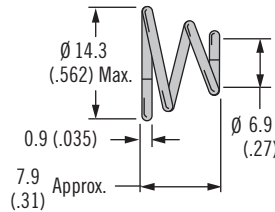

Cupped Washer

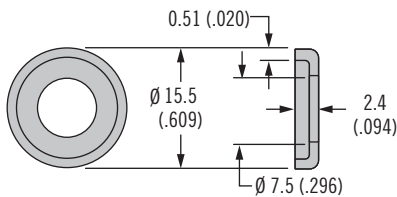

Flat Wear Washer

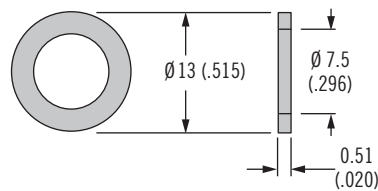

Material and Finish

See table

Installation Notes

For standard retainers use tool



Part number 85-0-22543-11

82

85

D8

D9

D1

D4

D5

D7

NY



Type	Part Number	Material	Adjustment Value
Push-on - Stainless steel	85-34-201-20	Stainless steel	Add 0.33 (.013)
Push-on - Plastic	85-34-301-12	Nylon, black	Add 0.76 (.030)
Push-on - Neoprene	85-33-101-27	Neoprene, black	Add 1.22 (.048)
Sealing washer	85-43-201-38	Neoprene nitrile rubber, black	Add 0.51 (.020)
Ejector spring	14-18-150-24	Stainless steel	Add 1.00 (.039)
Cupped washer	85-46-101-39	Nylon, white	Add 0.51 (.020)
	85-46-101-41	Nylon, black	
Flat wear washer	85-46-103-39	Nylon, white	Add 0.51 (.020)

Part Number

See table

Adjustment value:

When using accessories the components add thickness

Add the adjustment value to your outer panel thickness (P) when calculating TMT (see page 435 for example)