

REVISION HISTORY			
REV	DATE	BY	DESCRIPTION
J	29OCT2019	CMS/CDW	PRN: P2019-2690

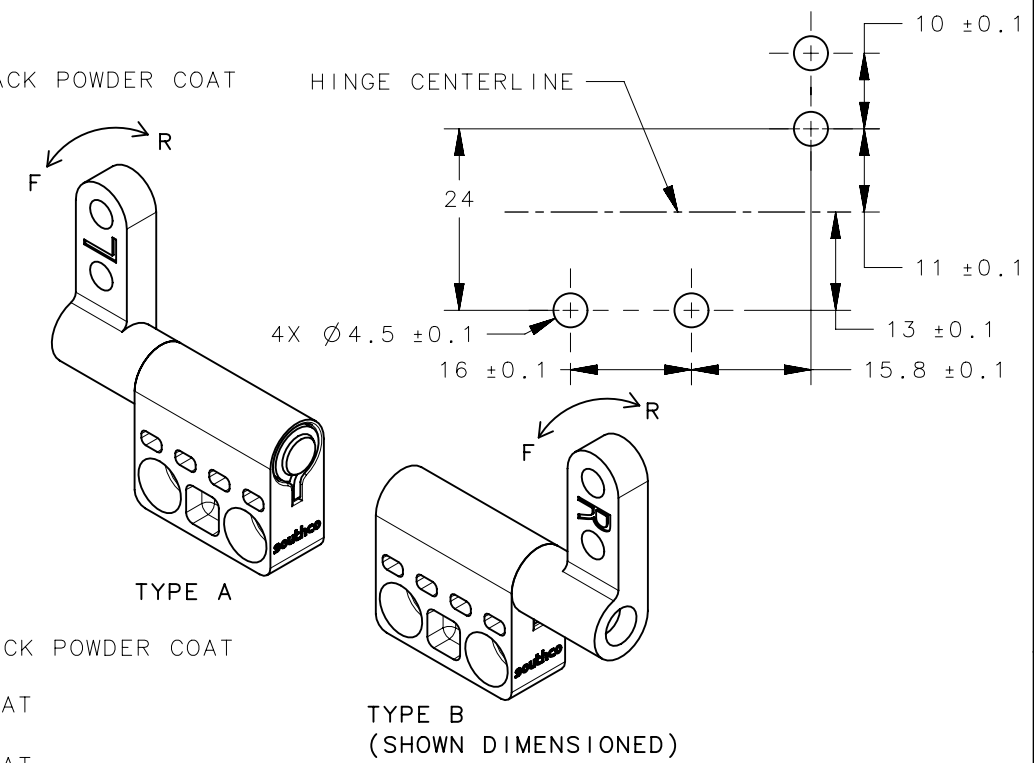

PART NUMBER	DESCRIPTION	FINISH
ST-10A-XXXXX-33	ASSEMBLY-AS CAST	NATURAL
ST-10A-XXXXX-50	ASSEMBLY-COATED	BLACK POWDER COAT

PART NUMBER		STATIC TORQUE ±20%	
TYPE A	TYPE B	FORWARD N-m(in-lbf)	REVERSE N-m(in-lbf)
ST-10A-50SA-XX	ST-10A-50SB-XX	.56(5)	.56(5)
ST-10A-160SA-XX	ST-10A-160SB-XX	1.8(16)	1.8(16)
ST-10A-160FA-XX	ST-10A-160FB-XX	1.8(16)	1.08(9.6 REF)
ST-10A-200SA-XX	ST-10A-200SB-XX	2.26(20)	2.26(20)
ST-10A-200FA-XX	ST-10A-200FB-XX	2.26(20)	1.36(12 REF)
ST-10A-160RA-XX	ST-10A-160RB-XX	1.08(9.6 REF)	1.8(16)
ST-10A-200RA-XX	ST-10A-200RB-XX	1.36(12 REF)	2.26(20)

- NOTE:
- MATERIAL AND FINISH:
HOUSING AND ADAPTER-ZINC ALLOY,
FOR FINISH SEE TABLE.
SHAFT AND TORQUE ELEMENTS-HARDENED STEEL.
 - INSTALL HINGE USING A NO.8 OR M4 SOCKET
HEAD CAP SCREW.
 - FOR PROPER FUNCTION, ASSEMBLY MUST INCLUDE
(1) TYPE "A" AND (1) TYPE "B" HINGE.
 - DIMENSIONS INDICATE AS-BUILT CONDITION.
LEAF TO LEAF SPACING WILL SELF ADJUST
DURING OPERATION.
 - PERFORMANCE TORQUE TOLERANCE OVER 20,000
CYCLES.

THIRD ANGLE PROJECTION				 CONNECT • CREATE • INNOVATE			
MILLIMETERS [IN]							
SURFACE AREA		TOLERANCES UNLESS OTHERWISE NOTED		DESCRIPTION ST-10 HINGE ASSEMBLY			
VOLUME		TOLERANCES:		SIZE	SYSTEM	DWG NO.	
PROPRIETARY ITEM		0 - 3 < ±0.15		A4	NX	J-ST-10A	
EXCEPT FOR USES EXPRESSLY GRANTED IN WRITING, INFORMATION DISCLOSED HEREON IS CONFIDENTIAL AND ALL RIGHTS, PATENT AND OTHERWISE, ARE RESERVED BY SOUTHCO, INC.		3 - 10 < ±0.20		DRAWN BY		DATE	SCALE
		10 - 50 < ±0.25		JM/AS		21FEB2006	1:1
PER ASME Y14.5M-1994							SHEET 1 OF 1