

REVISION HISTORY

REV	DATE	BY	DESCRIPTION
G	19FEB2018	MJS/RMO	PRN: P2018-0410

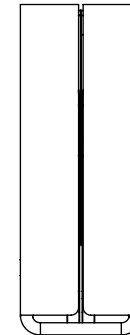
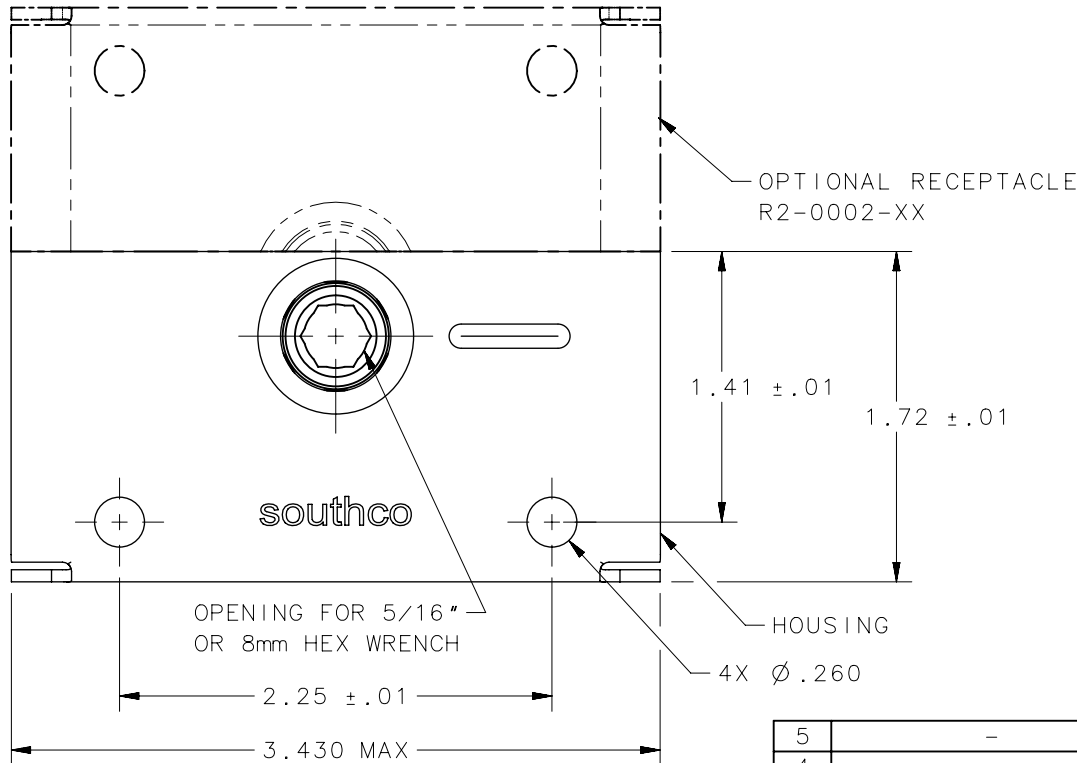
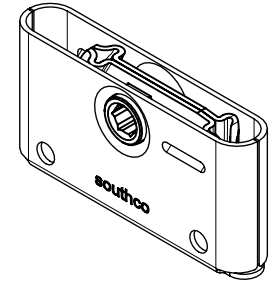
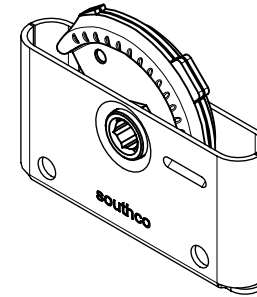
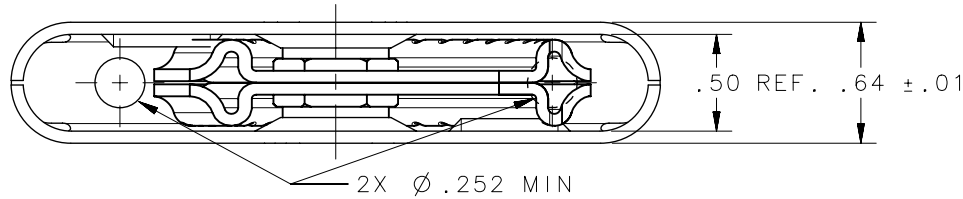

5	-	1	HOUSING	SEE NOTE A	SEE NOTE A
4	-	1	CAM HALF, MALE	SEE NOTE A	SEE NOTE A
3	-	1	CAM HALF, FEMALE	SEE NOTE A	SEE NOTE A
2	-	1	HUB	SEE NOTE A	SEE NOTE A
1	R2-0055-XX	1	ASSEMBLY	SEE NOTE A	SEE NOTE A
NO.	PART NUMBER	QTY	TYPE OF COMPONENT	MATERIAL	FINISH

NOTES:

A. MATERIAL AND FINISH:
R2-0055-02
 CAMS, HUB, HOUSING, AND RECEPTACLE:
 CARBON STEEL, ZINC PLATED PLUS
 BRIGHT CHROMATE FINISH

R2-0055-17
 HUB: CARBON STEEL, ZINC PLATED PLUS
 BRIGHT CHROMATE FINISH
 CAM, HOUSING, AND RECEPTACLE:
 G90 GALVANIZED STEEL.



THIRD ANGLE PROJECTION	
INCHES [MM]	
TOLERANCES UNLESS OTHERWISE NOTED	
ALL DIMENSIONS WITHOUT TOLERANCES ARE FOR REFERENCE ONLY.	
PER ASME Y14.5M-1994	
PROPRIETARY ITEM	
EXCEPT FOR USES EXPRESSLY GRANTED IN WRITING, INFORMATION DISCLOSED HEREON IS CONFIDENTIAL AND ALL RIGHTS, PATENT AND OTHERWISE, ARE RESERVED BY SOUTHCO, INC.	

southco [®]			
CONNECT • CREATE • INNOVATE			
DESCRIPTION No. R2 ROTO LOCK			
SIZE A	SYSTEM NX	DWG NO. J-R2-0055	
DRAWN BY KWC	DATE 09NOV1993	SCALE 1:1	SHEET 1 OF 2

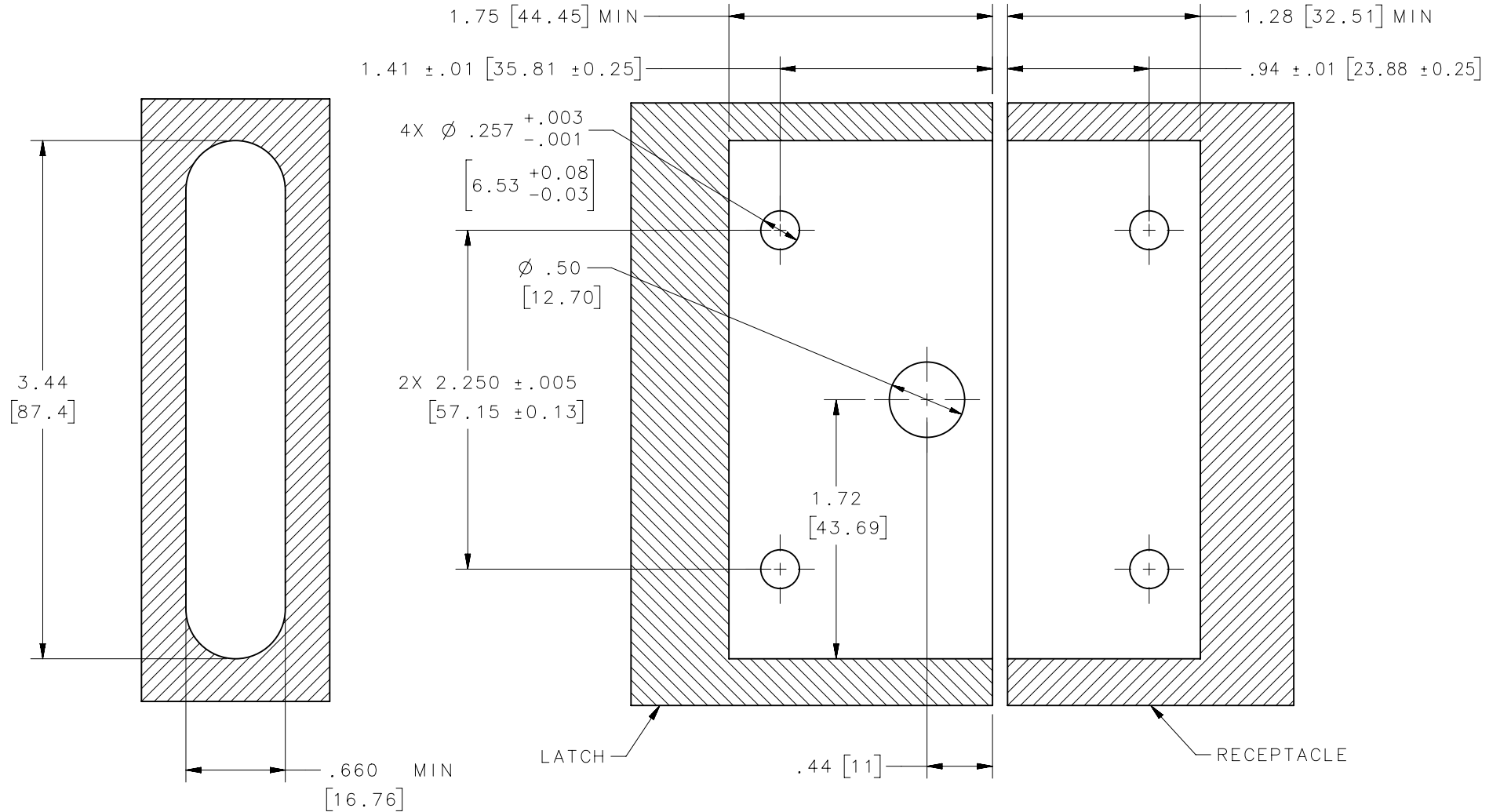
REVISION HISTORY			
REV	DATE	BY	DESCRIPTION
G	19FEB2018	MJS/RMO	PRN: P2018-0410

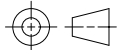

PANEL PREPARATION

	THIRD ANGLE PROJECTION 	 CONNECT • CREATE • INNOVATE			
	INCHES [MM]				
	TOLERANCES UNLESS OTHERWISE NOTED	DESCRIPTION			
	2 PLACE DECIMALS ± .01 3 PLACE DECIMALS ± .005 4 PLACE DECIMALS ± .0005	No. R2 ROTO LOCK PANEL PREPARATION			
	ANGLES ± 1°	SIZE A	SYSTEM NX	DWG NO. J-R2-0055	
<small>PROPRIETARY ITEM EXCEPT FOR USES EXPRESSLY GRANTED IN WRITING, INFORMATION DISCLOSED HEREON IS CONFIDENTIAL AND ALL RIGHTS, PATENT AND OTHERWISE, ARE RESERVED BY SOUTHCO, INC.</small>	PER ASME Y14.5M-1994	DRAWN BY KWC	DATE 09NOV1993	SCALE 1:1	SHEET 2 OF 2