

southco®

PROPRIETARY ITEM - EXCEPT FOR USES EXPRESSLY GRANTED IN WRITING INFORMATION DISCLOSED HEREON IS CONFIDENTIAL AND ALL RIGHTS PATENT AND OTHERWISE ARE RESERVED BY SOUTHCO, INC.

FLEXIBLE DRAW LATCH - CONCEALED MOUNTING SUBASSEMBLY (FRONT MOUNTED)

DATE	DRAWN	CHKD	SCALE	DRAWING NUMBER
26MAY2009	MJS		1:1	J-F7-530

REV	DATE	DRAWN/CHKD	DESCRIPTION	ITEM	PART NUMBER	MATERIAL	COLOR
A	26MAY2009	MJS	INITIAL DRAWING RELEASE	SUBASSEMBLY	F7-530	-	-
				HANDLE	-	TPE	BLACK
				BRACKET	-	GLASS REINFORCED NYLON	BLACK

MILLIMETERS

ALL DIMENSIONS WITHOUT TOLERANCES ARE FOR REFERENCE ONLY.

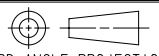

THIRD ANGLE PROJECTION

A4 PAPER SIZE

NOTES:

1. MOUNT USING (2) No. 10/M5 SCREWS OR 3/16 - 5mm RIVETS (NOT SUPPLIED).
2. NOTED DIMENSIONS ARE NOT TO SCALE AND REPRESENT DISTANCE WHEN FLEXIBLE DRAW LATCH HANDLE IS STRETCHED TO LATCHED POSITION OVER THE KEEPER.

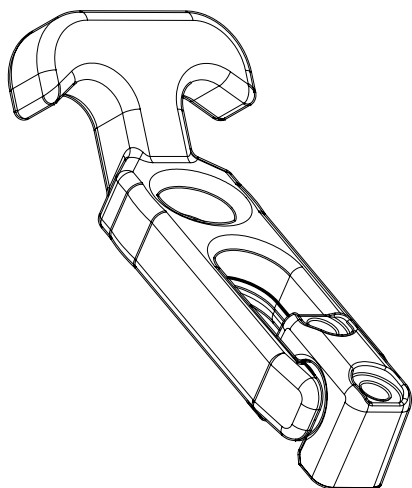
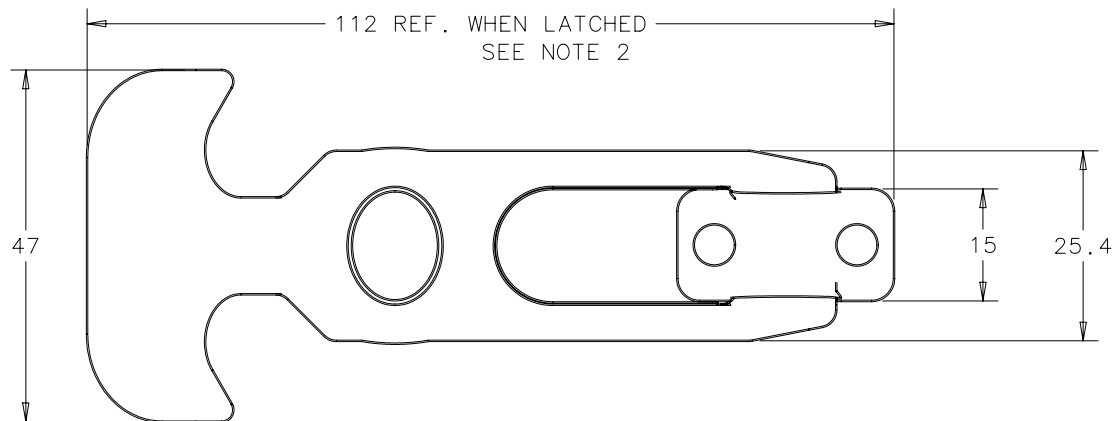

SCALE .75:1

