

REV.	DATE	BY-CHKD	REVISIONS	ITEM	COMPONENT	PART No.	MATERIAL	FINISH
A	02JAN2002	DLH	PRN: P2002-0764	ASSEMBLY		19-83-10		
B	17AUG2016	JPK CMS	PRN: P2016-1906	HANDLE-SHAFT SUB-ASSEMBLY				
				HANDLE			NYLON	BLACK
				SCREW			DIE CAST ZINC	BLACK CHROMATE
				PIN			18-9LW STAINLESS STEEL	SEE NOTE A
				BUSHING			IR/BR RUBBER	BLACK
				NUT			NYLON	BLACK
				CUP			NYLON	BLACK
				BRACKET			302 STAINLESS STEEL	PASSIVATED
				RETAINING RING			SPRING STEEL	ZINC PLATE- YELLOW CHROMATE

INSTALLATION

1. PREPARE RECTANGULAR HOLE IN DOOR AND ROUND HOLE IN FRAME.
2. SEAT LATCH IN RECTANGULAR HOLE.
3. POSITION BRACKET AND RETAINER OVER STUD. PLACE SET TOOL OVER RETAINER AND SHARPLY STRIKE TOOL * WITH HANDLE IN UP (UNLATCHED) POSITION, ADJUST NUT TO PROVIDE SATISFACTORY LATCHING TENSION.

*SOUTHCO TOOL No.17-10019-11 MUST BE ORDERED SEPARATELY.

NOTE A: PASSIVATED WITH BLACK OXIDE COATING.

SHIPPED UNASSEMBLED: ONE UNIT PER BAG.

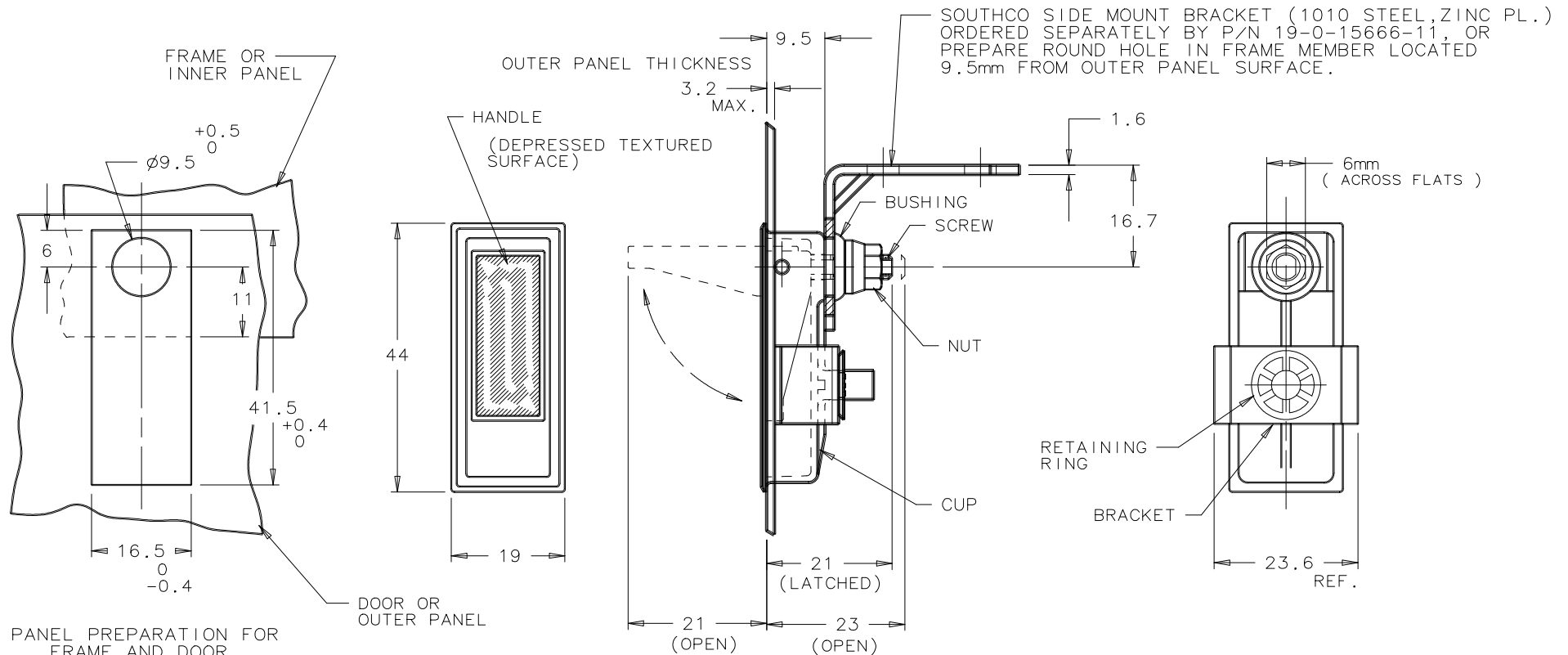

FORMATA 3/88