



SOUTHCO No. A1 ADJUSTABLE DRAW CATCH  
LATCH ASSEMBLY

DATE	DRAWN	CHKD	SCALE	DRAWING NUMBER
7-20-93	JGK		1:1	J-A1-11-702-50-M

REV.	DATE	BY-CHKD	REVISIONS	PART NUMBER	MATERIAL	FINISH			
				A1-11-702-50	SEE NOTE A	PASSIVATED			

NOTES:

TO OBTAIN MIN. GRIP LOCATE JAM NUT ON THE OPPOSITE SIDE OF THE ROD GUIDE

- A. LEVER, HOUSING - 304 STAINLESS STEEL
- JAM NUT, ROD GUIDE & PIN - 300 SERIES STAINLESS STEEL
- ROD, RIVETS - 302 STAINLESS STEEL

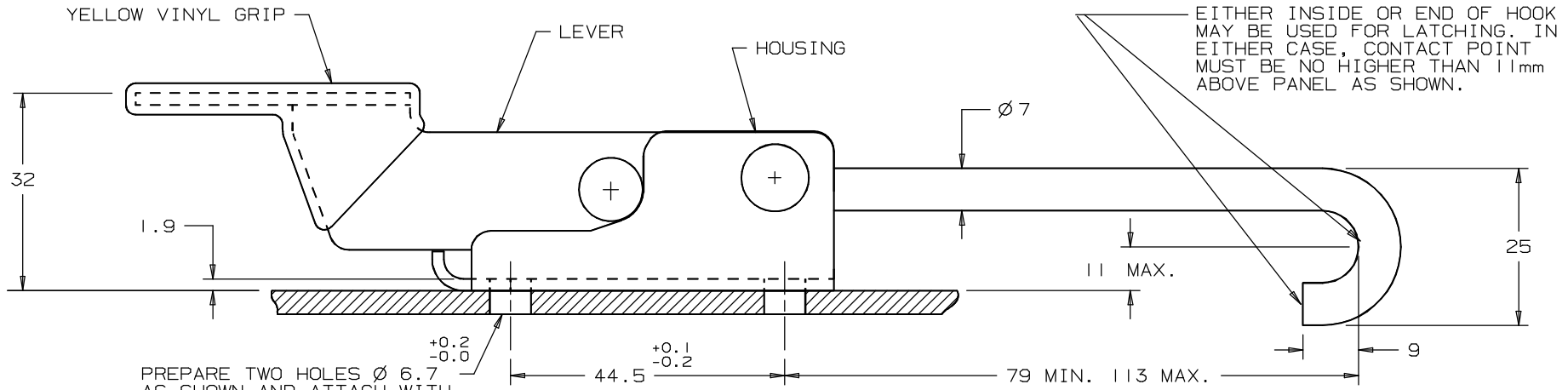
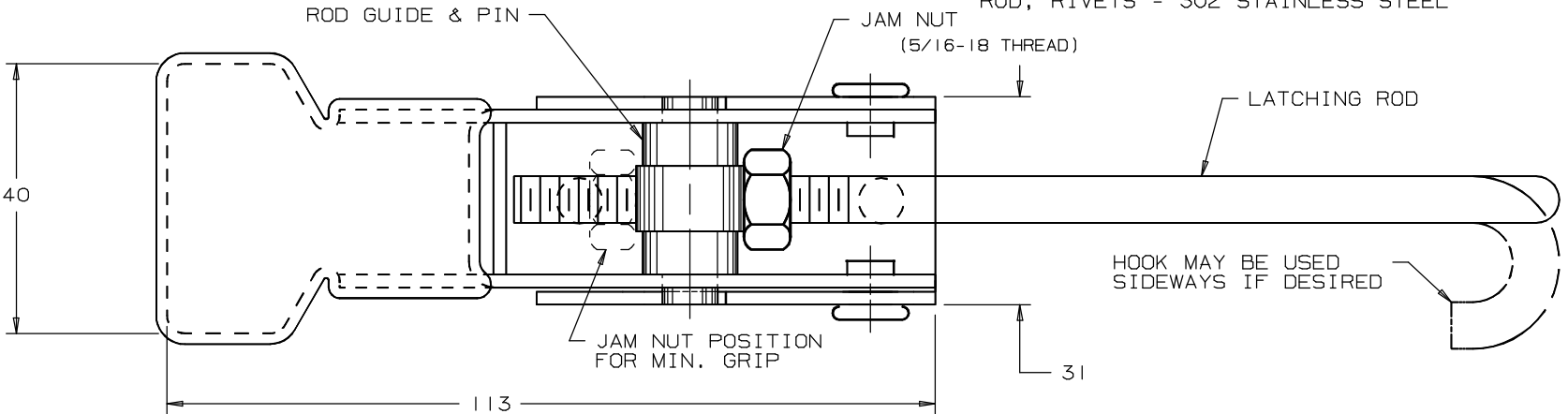

PREPARE TWO HOLES  $\varnothing 6.7$  AS SHOWN AND ATTACH WITH M6 SCREWS OR RIVETS.

FORMATA 3/88

PROPRIETARY ITEM - EXCEPT FOR USES EXPRESSLY GRANTED IN WRITING INFORMATION DISCLOSED HEREON IS CONFIDENTIAL AND ALL RIGHTS PATENT AND OTHERWISE ARE RESERVED BY SOUTHCO, INC.

ALL DIMENSIONS ARE IN MILLIMETERS.  
ALL DIMENSIONS WITHOUT TOLERANCES ARE REFERENCE.  
THIRD ANGLE PROJECTION DRAWING.

DRAWING NUMBER  
J-A1-11-702-50-M