

southco®

PROPRIETARY ITEM - EXCEPT FOR USES EXPRESSLY GRANTED IN WRITING INFORMATION DISCLOSED HEREON IS CONFIDENTIAL AND ALL RIGHTS PATENT AND OTHERWISE ARE RESERVED BY SOUTHCO, INC.

No. 93 SLAM - ACTION PUSH BUTTON LATCH
CORROSION - RESISTANT

DATE	DRAWN	CHKD	SCALE	DRAWING NUMBER
04JAN1991	JAD		FULL	J-93-308

REV	DATE	DRAWN/CHKD	DESCRIPTION	ASSEMBLY	MATERIAL	FINISH
A	19APR1991	ACZ	PRN - 93 - 113	93-308	SEE NOTE A	SEE NOTE A
B	14MAY1991	CRW	ADDED TOLERANCE TO MOUNTING HOLE	93-308B	SEE NOTE A	SEE NOTE A
C	02JUN1993	JGK	PRN: 96 - 106 & M3 WAS 3.5mm			
D	15APR1994	RDG	PRN: 93 - 144			
E	21MAR1995	RDG	PRN: 93 - 158			
F	14APR2008	ACH/MJS	PRN: P2008-0391			
G	21JAN2013	DJK/BGL	PRN: P2013-0187			

INCHES

TOLERANCES UNLESS OTHERWISE NOTED

TWO PLACE (.XX) ±.03
THREE PLACE (.XXX) ±.005
ANGLES ±1°



THIRD ANGLE PROJECTION

A
PAPER
SIZE

NOTES:

- A. MATERIAL AND FINISH
KEEPER, CAM SPRING & LOCKWASHER: STAINLESS STEEL, PASSIVATED
MOUNTING NUT & HOUSING: GLASS REINFORCED NYLON, BLACK
PAWL SPRING: STAINLESS STEEL, NATURAL
PULL TAB: NYLON, BLACK
INTERNAL CAM: GLASS REINFORCED NYLON/SILICONE, BLACK
KNOB & KNOB PLUG: THERMOPLASTIC POLYESTER, BLACK
PAWL: ACETAL, BLACK

B. 7.9 N-m (70 in-lbs) MAX TIGHTENING TORQUE

ASSEMBLY PART NUMBER 93-308

ASSEMBLY CONSISTS OF ONE LATCH SUB-ASSEMBLY AND HARDWARE, PACKAGED ONE COMPLETE ASSEMBLY PER BAG.

ASSEMBLY PART NUMBER 93-308-B

SAME AS ABOVE ASS'Y EXCEPT LATCH SUB-ASS'Y AND HARDWARE ARE SHIPPED SEPARATELY.

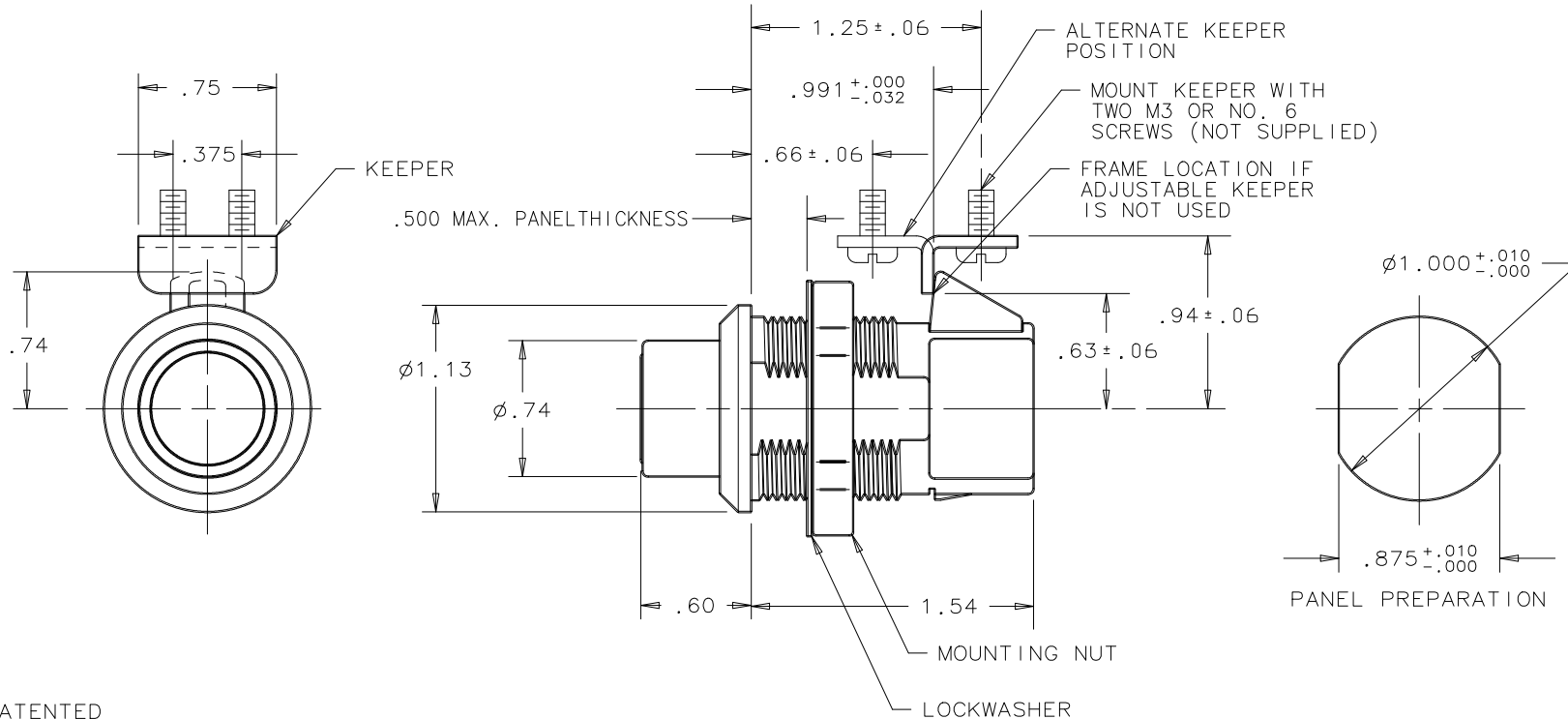

PATENTED