

southco

PROPRIETARY ITEM - EXCEPT FOR USES EXPRESSLY GRANTED IN WRITING INFORMATION DISCLOSED HEREON IS CONFIDENTIAL AND ALL RIGHTS PATENT AND OTHERWISE ARE RESERVED BY SOUTHCO, INC.

LIFT AND TURN COMPRESSION LATCH
NON-LOCKING - NO CUP

DATE	DRAWN	CHKD	SCALE	DRAWING NUMBER
17DEC2007	CW	MJS	.6:1	J-N2-2-100

REV	DATE	DRAWN/CHKD	DESCRIPTION	ITEM	PART NUMBER	MATERIAL	FINISH
A	29OCT2008	JSS	PRN:P2008-1172	ASSEMBLY (STEEL)	N2-2-100-01-XX	-	SEE FINISH TABLE
B	13APR2009	ACH/MJS	PRN:P2009-0429	HANDLE	-	ALUMINIUM	SEE FINISH TABLE
C	28OCT2010	RMD/LBT	PRN:P2010-0818	SLEEVE	-	STAINLESS STEEL	PASSIVATED
D	04MAY2018	CMS/MDW	PRN: P2018-1101	SLEEVE NUT	-	STAINLESS STEEL	PASSIVATED
				TAB WASHER	-	STAINLESS STEEL	PASSIVATED
				SHAFT	-	STAINLESS STEEL	PASSIVATED
				RIVET PIN	-	STAINLESS STEEL	PASSIVATED
				SPRING	-	STAINLESS STEEL	PASSIVATED
				BRASS WEAR WASHER	-	BRASS	NATURAL
				STOP PIN	-	STAINLESS STEEL	PASSIVATED
				M12 HEX NUT (2)	-	STEEL	ZINC ALLOY PLATE BRIGHT CHROMATE
				M12 LOCK WASHER (2)	-	STAINLESS STEEL	PASSIVATED
				LUBRICANT	-	SEE NOTE A	BLACK
				PAWL WASHERS (2)	-	STAINLESS STEEL	PASSIVATED

AVAILABLE GRIP RANGES
STANDARD PAWLS (SOLD SEPARATELY)

PART NUMBER	GRIP RANGE	PAWL TYPE
N2-21-101-YY	0 - 15	DEEP OFFSET
N2-21-102-YY	15 - 30	OFFSET
N2-21-103-YY	30 - 45	FLAT
N2-21-102-YY	45 - 60	OFFSET
N2-21-101-YY	60 - 75	DEEP OFFSET

MATERIAL	
-YY	STEEL
-12	STEEL
-24	STAINLESS STEEL

FINISH TABLE	
-XX	FINISH
-5	BLACK POWDER COAT

MILLIMETERS

ALL DIMENSIONS WITHOUT TOLERANCES ARE FOR REFERENCE ONLY.



THIRD ANGLE PROJECTION

A3 PAPER SIZE

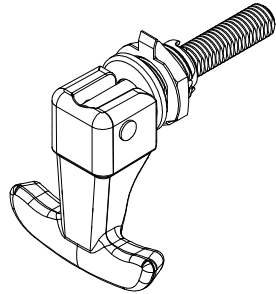

NOTES:

- A. LUBRICANT MATERIAL: OIL BASED GREASE WITH MOLYBDENUM DISULFIDE ADDITIVES.
- B. ASSEMBLY INSTRUCTIONS:
 1. INSERT THE HANDLE SUB-ASSEMBLY THROUGH THE DOUBLE-D HOLE.
 2. INSTALL THE TAB WASHER THEN THE SLEEVE NUT OVER THE SLEEVE.
 3. TIGHTEN THE SLEEVE NUT TO 25 N·m (MAX) THEN BEND THE TWO TABS OVER THE NUT.
 4. INSTALL THE FIRST M12 HEX NUT, M12 WASHER, THEN PAWL, AND THE SECOND WASHER AND HEX NUT ONTO THE SHAFT.
 5. ADJUST THE PAWL AND LOCK NUTS ACCORDINGLY AND TIGHTEN TO 20-25 N·m (MAX).
 - 5A. IF USING M12 PAWL WASHERS: AFTER ADJUSTING PAWL AND LOCK NUTS, BEND TABS OF M12 PAWL WASHERS OVER M12 LOCK NUTS.
- C. PACKAGING:

LATCH AND HARDWARE PACK IS PACKAGED IN PLASTIC BAG, PACKED TOGETHER IN SMALL CARDBOARD BOX.
18 ASSEMBLIES PER CARDBOARD CONTAINER,
WHEN ORDERING, SPECIFY QTY. IN MULTIPLES OF 16.

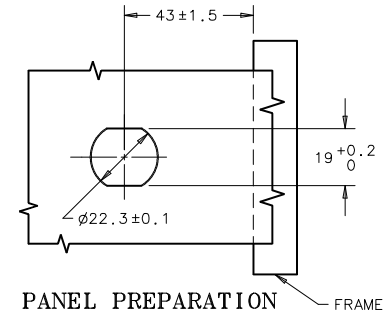

PANEL PREPARATION

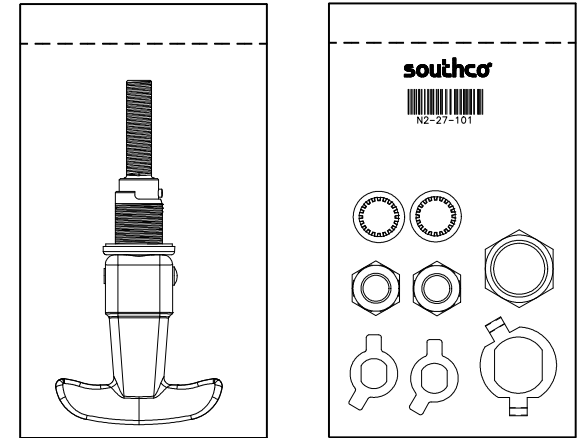
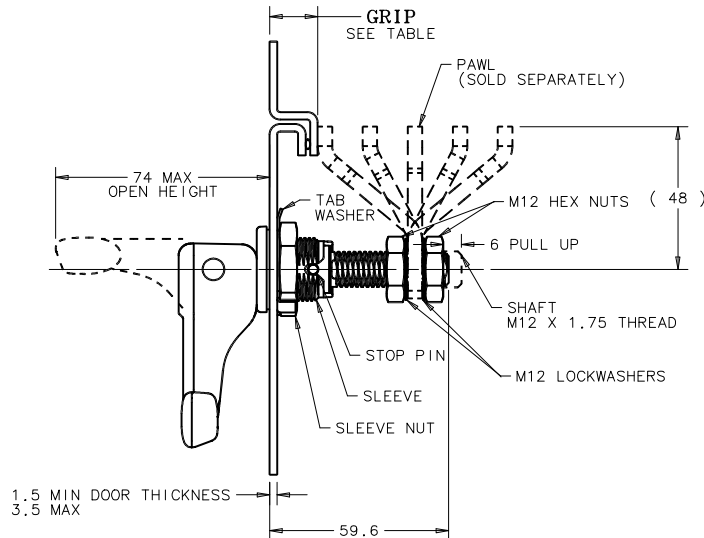
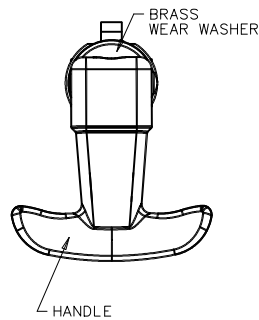

PACKAGING

southco

PROPRIETARY ITEM - EXCEPT FOR USES EXPRESSLY GRANTED IN WRITING INFORMATION DISCLOSED HEREON IS CONFIDENTIAL AND ALL RIGHTS PATENT AND OTHERWISE ARE RESERVED BY SOUTHCO, INC.

LIFT AND TURN COMPRESSION LATCH
NON-LOCKING - NO CUP

DATE	DRAWN	CHKD	SCALE	DRAWING NUMBER
17DEC2007	CW	MJS	.6:1	J-N2-2-100

REV	DATE	DRAWN/CHKD	DESCRIPTION	ITEM	PART NUMBER	MATERIAL	FINISH
A	29OCT2008	JSS	PRN:P2008-1172	ASSEMBLY (SS)	N2-2-100-01-XX	-	SEE FINISH TABLE
B	13APR2009	ACH/MJS	PRN:P2009-0429	HANDLE	-	STAINLESS STEEL	SEE FINISH TABLE
C	28OCT2010	RMD/LBT	PRN:P2010-0818	SLEEVE	-	STAINLESS STEEL	PASSIVATED
D	04MAY2018	CMS/MDW	PRN: P2018-1101	SLEEVE NUT	-	STAINLESS STEEL	PASSIVATED
				TAB WASHER	-	STAINLESS STEEL	PASSIVATED
				SHAFT	-	STAINLESS STEEL	PASSIVATED
				RIVET PIN	-	STAINLESS STEEL	PASSIVATED
				SPRING	-	STAINLESS STEEL	PASSIVATED
				BRASS WEAR WASHER	-	BRASS	NATURAL
				STOP PIN	-	STAINLESS STEEL	PASSIVATED
				M12 HEX NUT (2)	-	STEEL	ZINC ALLOY PLATE BRIGHT CHROMATE
				M12 LOCK WASHER (2)	-	STAINLESS STEEL	PASSIVATED
				LUBRICANT	-	SEE NOTE A	BLACK
				PAWL WASHERS (2)	-	STAINLESS STEEL	PASSIVATED

MILLIMETERS

ALL DIMENSIONS WITHOUT TOLERANCES ARE FOR REFERENCE ONLY.



THIRD ANGLE PROJECTION

A3 PAPER SIZE

**AVAILABLE GRIP RANGES
STANDARD PAWLS (SOLD SEPARATELY)**

PART NUMBER	GRIP RANGE	PAWL TYPE
N2-21-101-YY	0 - 15	DEEP OFFSET
N2-21-102-YY	15 - 30	OFFSET
N2-21-103-YY	30 - 45	FLAT
N2-21-102-YY	45 - 60	OFFSET
N2-21-101-YY	60 - 75	DEEP OFFSET

MATERIAL	
-YY	MATERIAL
-12	STEEL
-24	STAINLESS STEEL

FINISH TABLE	
-XX	FINISH
-20	POLISHED STAINLESS

NOTES:

- A. LUBRICANT MATERIAL: OIL BASED GREASE WITH MOLYBDENUM DISULFIDE ADDITIVES.
- B. ASSEMBLY INSTRUCTIONS:
1. INSERT THE HANDLE SUB-ASSEMBLY THROUGH THE DOUBLE-D HOLE.
 2. INSTALL THE TAB WASHER THEN THE SLEEVE NUT OVER THE SLEEVE.
 3. TIGHTEN THE SLEEVE NUT TO 25 N·m (MAX) THEN BEND THE TWO TABS OVER THE NUT.
 4. INSTALL THE FIRST M12 HEX NUT, M12 WASHER, THEN PAWL, AND THE SECOND WASHER AND HEX NUT ONTO THE SHAFT.
 5. ADJUST THE PAWL AND LOCK NUTS ACCORDINGLY AND TIGHTEN TO 20-25 N·m (MAX).
 - 5A. IF USING M12 PAWL WASHERS: AFTER ADJUSTING PAWL AND LOCK NUTS, BEND TABS OF M12 PAWL WASHERS OVER M12 LOCK NUTS.
- C. PACKAGING:
LATCH AND HARDWARE PACK IS PACKAGED IN PLASTIC BAG, PACKED TOGETHER IN SMALL CARDBOARD BOX, 18 ASSEMBLIES PER CARDBOARD CONTAINER, WHEN ORDERING, SPECIFY QTY. IN MULTIPLES OF 16.

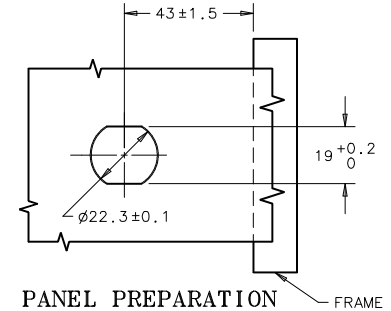
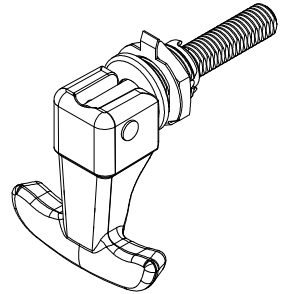

PANEL PREPARATION

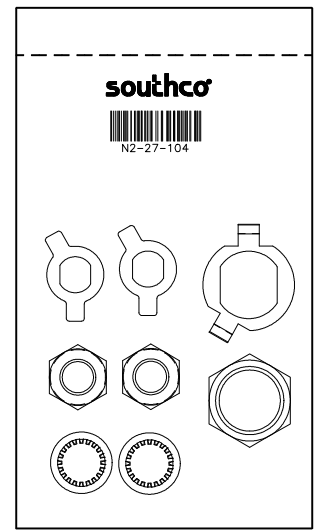
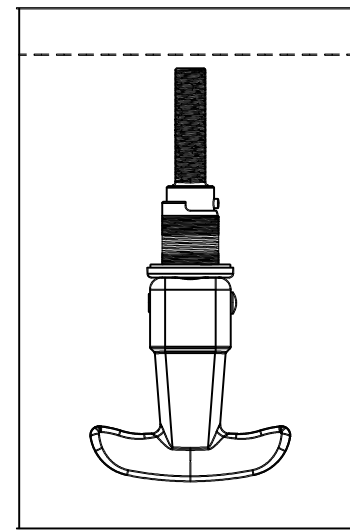
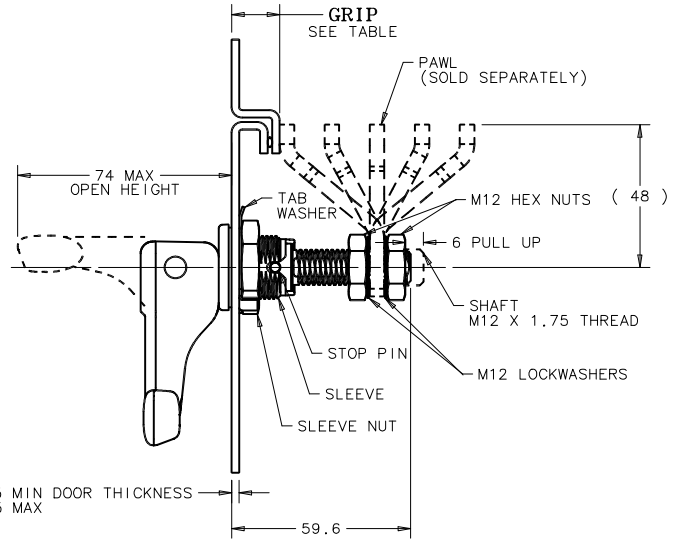
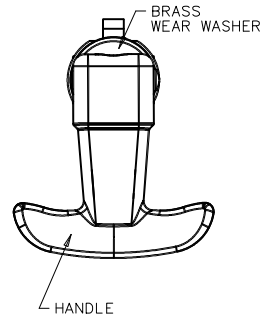

PACKAGING