

REVISION HISTORY			
REV	DATE	BY	DESCRIPTION
J	16MAY2022	GJL/MBT	PRN: P2022-0905

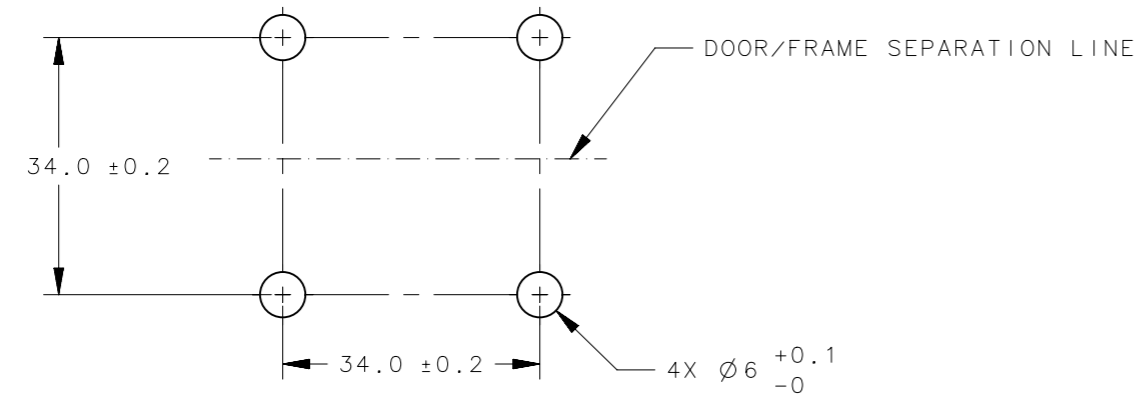

PANEL PREPARATION

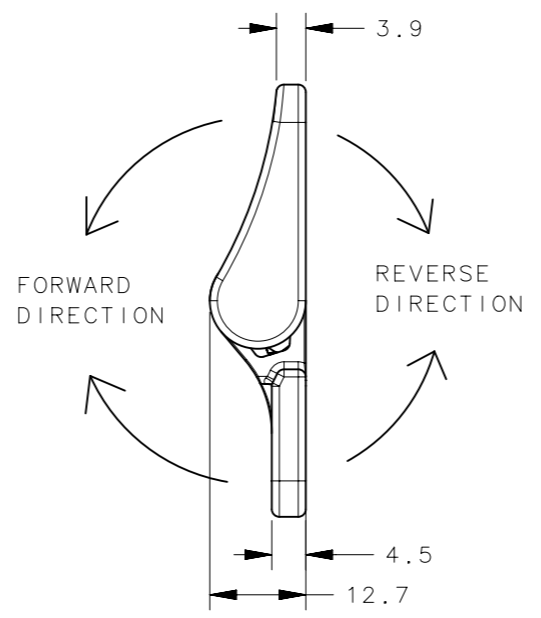
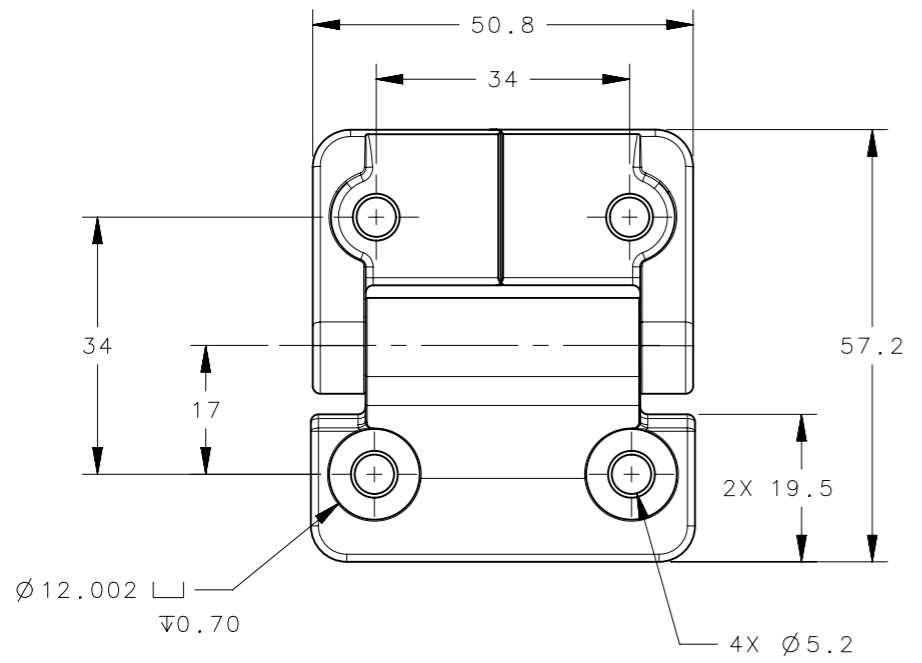
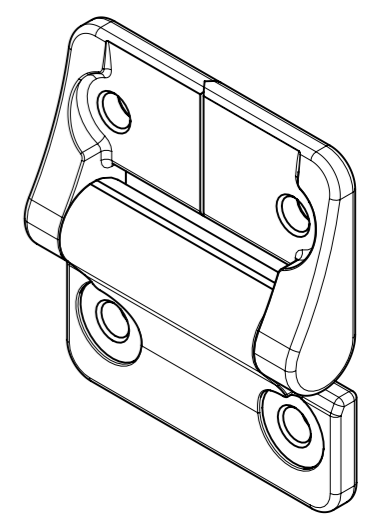

PART NUMBER	FORWARD TORQUE	REVERSE TORQUE
E6-10-400-XX	SEE NOTE 1	
E6-10-408-XX	0.9 N-m (8.0 in-lbs)	
E6-10-416-XX	1.8 N-m (16.0 in-lbs)	
E6-10-420-XX	2.3 N-m (20.0 in-lbs)	
E6-10-430-XX	3.4 N-m (30.0 in-lbs)	
E6-10-420F-XX	2.3 N-m (20.0 in-lbs)	1.5 N-m (13.6 in-lbs)
E6-10-430F-XX	3.4 N-m (30.0 in-lbs)	2.3 N-m (20.4 in-lbs)
E6-10-440F-XX	4.5 N-m (40.0 in-lbs)	3.1 N-m (27.3 in-lbs)
E6-10-420R-XX	1.5 N-m (13.6 in-lbs)	2.3 N-m (20.0 in-lbs)
E6-10-430R-XX	2.3 N-m (20.4 in-lbs)	3.4 N-m (30.0 in-lbs)
E6-10-440R-XX	3.1 N-m (27.3 in-lbs)	4.5 N-m (40.0 in-lbs)

E6-10-4XXX-10	ASSEMBLY - COATED	WHITE POWDER
E6-10-4XXX-70	ASSEMBLY - COATED	SILVER POWDER
E6-10-4XXX-50	ASSEMBLY - COATED	BLACK POWDER
E6-10-4XXX-33	ASSEMBLY - AS CAST	NATURAL
PART NO.	DESCRIPTION	FINISH

- NOTES:
- FREE PIVOT HINGE. (TORQUE TO ROTATE LESS THAN 1 lb-in)
 - PERFORMANCE TORQUE TOLERANCE ±20%
 - DESIGNED TO ACCEPT M5 OR No. 10 SCREW OR EQUIVALENT
 - MATERIAL AND FINISH:
HINGE LEAVES: DIE CAST ZINC, SEE TABLE FOR FINISH
SHAFT & PIN: STEEL
O-RINGS: BUNA-N RUBBER
BEARINGS: DIE CAST ZINC

CPB NUMBER 2018-0373	THIRD ANGLE PROJECTION	
SURFACE AREA	MILLIMETERS [IN]	
VOLUME	TOLERANCES UNLESS OTHERWISE NOTED	DESCRIPTION E6 400 SERIES HINGE ASSEMBLY
PROPRIETARY ITEM EXCEPT FOR USES EXPRESSLY GRANTED IN WRITING, INFORMATION DISCLOSED HEREON IS CONFIDENTIAL AND ALL RIGHTS, PATENT AND OTHERWISE, ARE RESERVED BY SOUTHCO, INC.	ALL DIMENSIONS WITHOUT TOLERANCES ARE FOR REFERENCE ONLY.	SIZE A3 SYSTEM NX DWG NO. J-E6-10-4-50
PER ASME Y14.5M-1994	DRAWN BY AS	DATE 18AUG2006 SCALE 1:1 SHEET 1 OF 1