

PART NUMBER	'H'
D4-S3-100	2.54
D4-S3-125	3.18
D4-S3-150	3.8
D4-S3-175	4.44
D4-S3-200	5.08
D4-S3-225	5.72
D4-S3-250	6.35
D4-S3-275	6.98
D4-S3-300	7.62
D4-S3-125SS	3.18
D4-S3-150SS	3.8
D4-S3-175SS	4.44
D4-S3-200SS	5.08
D4-S3-225SS	5.72

REVISION HISTORY			
REV	DATE	BY	DESCRIPTION
B	10JUL2017	SPD/YGC	PRN: P2017-1649

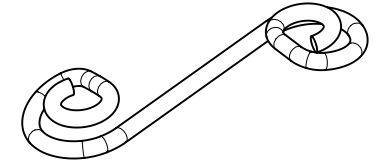

SCALE 2:1

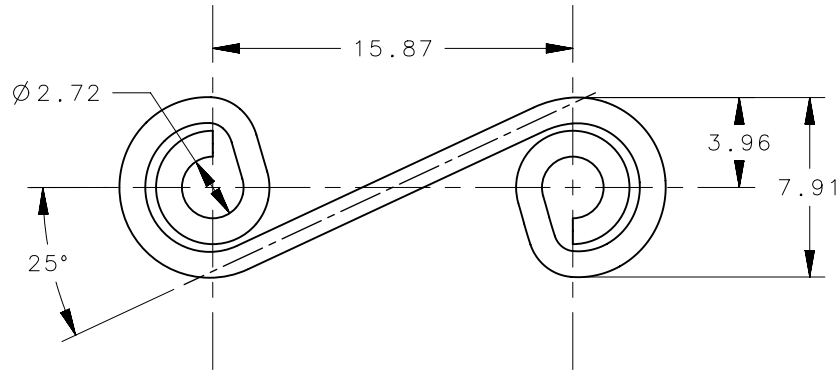
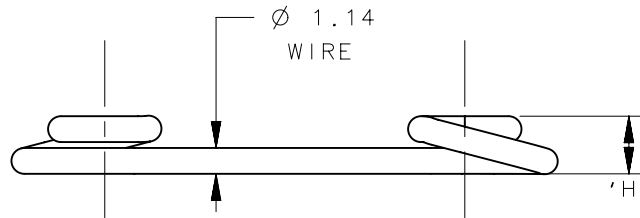

D4-S3-XXXCBY	SPRING	STEEL	YELLOW CHROMATE	AEROSPACE-USA
D4-S3-XXXSS	SPRING	STAINLESS STEEL	PASSIVATION	COMMERCIAL
D4-S3-XXX	SPRING	STEEL	ZINC PLATE	COMMERCIAL
PART NUMBER	TYPE OF COMPONENT	MATERIAL	FINISH	GENERAL NOTES

THIRD ANGLE PROJECTION					southco [®] CONNECT • CREATE • INNOVATE		
MILLIMETERS [IN]							
TOLERANCES UNLESS OTHERWISE NOTED		DESCRIPTION			SPRING - S3 TYPE		
ALL DIMENSIONS WITHOUT TOLERANCES ARE FOR REFERENCE ONLY.		SIZE	SYSTEM	DWG NO.	J-D4-S3-XXX		
<small>EXCEPT FOR USES EXPRESSLY GRANTED IN WRITING, INFORMATION DISCLOSED HEREON IS CONFIDENTIAL AND ALL RIGHTS, PATENT AND OTHERWISE, ARE RESERVED BY SOUTHCO, INC.</small>		A4	NX				
PER ASME Y14.5M-1994		DRAWN BY	DATE	SCALE	SHEET		
		MJW	19JUN2006	3:1	1 OF 1		